

FLOOR-EQUIPMENT-PARTS.COM

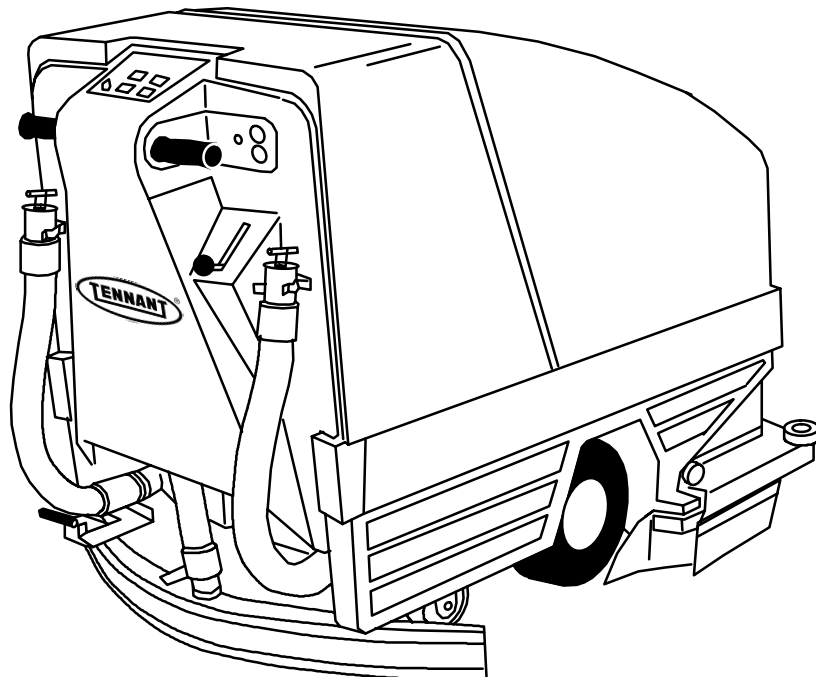

1465
1480
1490

(Operator Manual)



MM185
Rev. 11 (9-94)



This manual is furnished with each new TENNANT Model 1465, 1480, and 1490. It provides necessary operating and preventive maintenance instructions. Read this manual completely and understand the machine before operating or servicing it.

This manual covers all machine variations and standard options. The instruction portion of the manual consists of the Specification, Operation, Maintenance, and Appendix sections. The parts portion consists of How to use this Manual; 1465 Parts; 1480 Parts; 1490 Parts; Options; Breakdowns; and Cross Reference sections.

All right side and left side references to the machine are determined by facing the direction of forward travel. All hardware considered to be of a common nature or locally available has been omitted from the parts sections. Be aware that this machine may contain metric hardware. Make sure you use equivalent hardware when replacement becomes necessary.

This machine will provide excellent service. However, the best results will be obtained at minimum costs if:

- The machine is operated with reasonable care.
- The machine is maintained regularly – per the maintenance instructions provided.
- The machine is maintained with TENNANT supplied or equivalent parts.

Parts and supplies may be ordered by phone or mail from any TENNANT parts and service center, distributor, or from any of the TENNANT subsidiaries. Before ordering parts or supplies, be sure to have your machine model number and serial number handy. Fill out the data block below for future reference. The telephone numbers, telex numbers, mailing addresses, and locations of those outlets are listed in the Customer Documents section of the manual.

| |
|--|
| MACHINE DATA <i>Please fill out at time of installation.</i> |
| Machine Serial Number – _____ |
| Engine Serial Number – _____ |
| Sales Representative – _____ |
| Customer Number – _____ |
| Date of Installation – _____ |
| Manual Number – MM185 |
| Revision: 11 |
| Published: 9-94 |

Trademark Registered in: Austria, Benelux, Denmark, England, France, Germany, Italy, Spain, Switzerland, United States, Argentina, Australia, Canada, Japan, Mexico, Sweden, by TENNANT, Minneapolis, Minnesota, U.S.A.

Copyright 1988, 1989, 1990, 1991, 1992, 1993, 1994 TENNANT, Printed in U.S.A.

SAFETY PRECAUTIONS

The following symbols are used throughout this manual as indicated in their descriptions:



WARNING: To Warn Of Hazards Or Unsafe Practices Which Could Result In Severe Personal Injury Or Death.

FOR SAFETY: To Identify Actions Which Must Be Followed For Safe Operation Of Equipment.

The following information signals potentially dangerous conditions to the operator or equipment. Read this manual carefully. Know when these conditions can exist. Locate all safety devices on the machine. Then, take necessary steps to train machine operating personnel. Report machine damage or faulty operation immediately. Do not use the machine if it is not in proper operating condition.

FOR SAFETY:

1. **Do Not Operate Machine:**
 - Unless Trained And Authorized.
 - Unless Operation Manual Is Read And Understood.
 - In Flammable Or Explosive Areas Unless Designed For Use In Those Areas.
 - In Areas With Possible Falling Objects Unless Equipped With Overhead Guard.
2. **Before Starting Machine:**
 - Make Sure All Safety Devices Are In Place And Operate Properly.
 - Check Brakes And Steering For Proper Operation (If So Equipped).
3. **When Using Machine:**
 - Go Slow On Grades And Slippery Surfaces.
 - Use Care When Backing Machine.
 - Do Not Carry Riders On Machine.
 - Always Follow Safety And Traffic Rules.
4. **Before Leaving Or Servicing Machine:**
 - Stop On Level Surface.
 - Set Parking Brake.
 - Turn Off Machine And Remove Key.

5. When Servicing Machine:

- Avoid Moving Parts. Do Not Wear Loose Jackets, Shirts, Or Sleeves When Working On Machine.
- Block Machine Tires Before Jacking Machine Up.
- Jack Machine Up At Designated Locations Only. Block Machine Up With Jack Stands.
- Use Hoist Or Jack Of Adequate Capacity To Lift Machine.
- Disconnect Battery Connections Before Working On Machine.
- Avoid Contact With Battery Acid.
- Use TENNANT Supplied Or Equivalent Replacement Parts.



WARNING: Batteries Emit Hydrogen Gas. Explosion Or Fire Can Result. Keep Sparks And Open Flame Away. Keep Covers Open When Charging.



WARNING: Flammable Materials Can Cause An Explosion Or Fire. Do Not Use Flammable Materials In Tank(s).



WARNING: Flammable Materials Or Reactive Metals Can Cause Explosion Or Fire. Do Not Pick Up.



WARNING: Hazardous Voltage. Shock Can Result. Disconnect Batteries Before Working On Machine. Only Qualified Personnel Should Work Inside Panel.

GENERAL INFORMATION

The following safety labels are mounted on the machine in the locations indicated. If these, or any label becomes damaged or illegible, install a new label in its place.

FOR SAFETY LABEL – LOCATED BELOW THE CONTROL PANEL.



BATTERY CHARGING WARNING LABEL – LOCATED NEXT TO THE MACHINE AND BATTERY CONNECTORS.

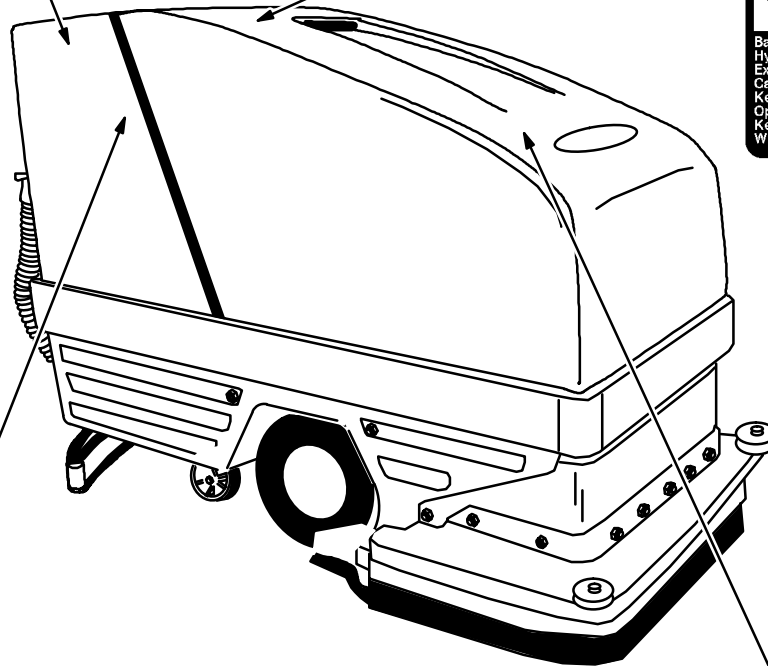

FLAMMABLE MATERIALS LABEL – LOCATED UNDER THE LEFT STEERING HANDLE

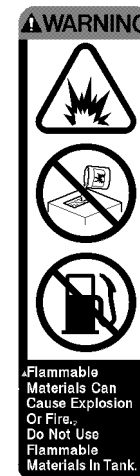

CLEANING AGENTS WARNING LABEL – LOCATED ON THE RECOVERY TANK.

04385

CONTENTS

| | Page | | Page |
|--|------|---|------|
| GENERAL INFORMATION | i | STEERING HANDLES | 2-7 |
| SAFETY PRECAUTIONS | i | RECOVERY TANK FULL INDICATOR | 2-7 |
| SPECIFICATIONS | 1-1 | BRUSH CIRCUIT BREAKER INDICATOR | 2-7 |
| MACHINE SPECIFICATIONS – 1465 . | 1-3 | HOUR METER | 2-7 |
| POWER TYPE | 1-3 | KEY-OPERATED ON-OFF SWITCH | 2-7 |
| POWER TRAIN | 1-3 | BATTERY DISCHARGE INDICATOR | 2-7 |
| STEERING | 1-3 | ES™ SWITCH | 2-7 |
| BRAKING SYSTEM | 1-3 | SQUEEGEE SWITCH | 2-8 |
| SUSPENSION SYSTEM | 1-3 | BRUSH PRESSURE SWITCH AND INDICATOR | 2-8 |
| SYSTEM FLUID CAPACITIES | 1-3 | SUPER SCRUB SWITCH | 2-8 |
| GENERAL MACHINE DIMENSIONS – CAPACITIES | 1-3 | SCRUB BRUSH SWITCH | 2-8 |
| MACHINE WEIGHTS | 1-3 | SOLUTION LEVER | 2-8 |
| GENERAL MACHINE PERFORMANCE | 1-3 | AUTO STOP SWITCH | 2-9 |
| MACHINE DIMENSIONS – 1465 | 1-4 | POWER WAND SWITCH | 2-9 |
| MACHINE SPECIFICATIONS – 1480 . | 1-5 | PRE-SWEEP™ BRUSH HANDLE . | 2-9 |
| POWER TYPE | 1-5 | PARKING BRAKE LEVER | 2-9 |
| POWER TRAIN | 1-5 | CIRCUIT BREAKERS | 2-9 |
| STEERING | 1-5 | MACHINE OPERATION | 2-10 |
| BRAKING SYSTEM | 1-5 | NORMAL SCRUBBING OPERATION | 2-10 |
| SUSPENSION SYSTEM | 1-5 | PRE-START CHECKLIST | 2-10 |
| SYSTEM FLUID CAPACITIES | 1-5 | TO START MACHINE | 2-10 |
| GENERAL MACHINE DIMENSIONS – CAPACITIES | 1-5 | TO FILL SOLUTION TANK | 2-10 |
| MACHINE WEIGHTS | 1-5 | TO SCRUB | 2-11 |
| GENERAL MACHINE PERFORMANCE | 1-5 | TO DRAIN AND CLEAN RECOVERY TANK | 2-11 |
| MACHINE DIMENSIONS – 1480 | 1-6 | POST OPERATION CHECKLIST – MACHINE ON | 2-13 |
| MACHINE SPECIFICATIONS – 1490 . | 1-7 | TO STOP MACHINE | 2-13 |
| POWER TYPE | 1-7 | POST OPERATION CHECKLIST – MACHINE OFF | 2-14 |
| POWER TRAIN | 1-7 | DOUBLE SCRUBBING OPERATION | 2-14 |
| STEERING | 1-7 | OPERATION ON GRADES | 2-14 |
| BRAKING SYSTEM | 1-7 | MACHINE TROUBLESHOOTING . | 2-15 |
| SUSPENSION SYSTEM | 1-7 | OPTIONS OPERATION | 2-16 |
| SYSTEM FLUID CAPACITIES | 1-7 | VACUUM WAND ATTACHMENT .. | 2-16 |
| GENERAL MACHINE DIMENSIONS – CAPACITIES | 1-7 | TO OPERATE VACUUM WAND ATTACHMENT | 2-16 |
| MACHINE WEIGHTS | 1-7 | POWER WAND | 2-17 |
| GENERAL MACHINE PERFORMANCE | 1-7 | TO OPERATE THE POWER WAND | 2-17 |
| MACHINE DIMENSIONS – 1490 | 1-8 | PRE-SWEEP™ | 2-19 |
| OPERATION | 2-1 | TO REMOVE PRE-SWEEP™ .. | 2-19 |
| PREPARATION FOR OPERATION ... | 2-3 | TO MOUNT THE PRE-SWEEP™ | 2-20 |
| AFTER UNCRATING AND BEFORE OPERATING MACHINE: | 2-3 | TRANSPORTING MACHINE | 2-22 |
| OPERATION OF CONTROLS | 2-4 | PUSHING OR TOWING MACHINE | 2-22 |
| MACHINE COMPONENTS | 2-4 | MACHINE JACKING | 2-22 |
| HOW IT WORKS | 2-5 | TO JACK UP MACHINE | 2-22 |
| INSTRUMENT PANEL SYMBOLS . | 2-5 | MACHINE TIE-DOWNS | 2-23 |
| CONTROLS AND INSTRUMENTS | 2-6 | MACHINE STORAGE | 2-24 |
| | | STORING MACHINE | 2-24 |

GENERAL INFORMATION

| | Page | | Page |
|-----------------------------------|------|--|------|
| MAINTENANCE | 3-1 | OPTIONS | 3-23 |
| RECOMMENDED FIRST 50-HOUR .. | | PRE-SWEEP™ | 3-23 |
| MACHINE INSPECTION | 3-3 | PRE-SWEEP™ BRUSH | 3-23 |
| MAINTENANCE CHART | 3-4 | TO REPLACE PRE-SWEEP™ | |
| LUBRICATION | 3-5 | BRUSH | 3-23 |
| REAR CASTERS | 3-5 | TO ADJUST PRE-SWEEP™ BRUSH | |
| WHEEL DRIVE CHAIN | 3-5 | PATTERN | 3-24 |
| ELECTRICAL SYSTEM | 3-6 | PRE-SWEEP™ BRUSH SIDE | |
| BATTERIES | 3-6 | SKIRTS | 3-24 |
| TO CHARGE BATTERIES | 3-7 | PRE-SWEEP™ BRUSH DRIVE | |
| ELECTRIC MOTORS | 3-8 | BELT | 3-24 |
| ELECTRICAL SCHEMATIC | 3-9 | TO REPLACE AND ADJUST THE | |
| BELTS AND CHAINS | 3-10 | BRUSH DRIVE BELT | 3-24 |
| WHEEL DRIVE CHAIN | 3-10 | PRE-SWEEP™ REAR SKIRT .. | 3-25 |
| STATIC DRAG CHAIN | 3-10 | DEBRIS HOPPER SLIT SKIRT . | 3-26 |
| SCRUB HEAD | 3-11 | PRE-SWEEP™ HOPPER SEALS | 3-26 |
| SCRUB HEAD | 3-11 | | |
| TO LEVEL SCRUB HEAD | 3-11 | APPENDIX | 4-1 |
| SCRUB BRUSHES | 3-12 | HARDWARE INFORMATION | 4-3 |
| TO REPLACE SCRUB BRUSHES | 3-12 | STANDARD BOLT TORQUE CHART | 4-3 |
| SCRUB HEAD FLOOR SKIRT | 3-13 | METRIC BOLT TORQUE CHART . | 4-3 |
| SOLUTION AND RECOVERY TANKS | 3-14 | BOLT IDENTIFICATION | 4-3 |
| SOLUTION TANK | 3-14 | THREAD SEALANT AND LOCKING | |
| SOLUTION VALVE | 3-14 | COMPOUNDS | 4-3 |
| RECOVERY TANK | 3-15 | | |
| TO DRAIN AND CLEAN RECOVERY | | HOW TO USE THIS MANUAL | 5-1 |
| TANK | 3-15 | IMPORTANT INFORMATION | 5-1 |
| SQUEEGEES | 3-17 | FINDING A TENNANT PART NUMBER | 5-2 |
| REAR SQUEEGEE | 3-17 | PLACING AN ORDER | 5-3 |
| TO REMOVE SQUEEGEE | | | |
| ASSEMBLY | 3-17 | 1465 MODEL PARTS | 6-1 |
| TO INSTALL SQUEEGEE | | Fig. 1 – Recommended General | |
| ASSEMBLY | 3-18 | Maintenance Items | 6-2 |
| TO REPLACE OR ROTATE | | Fig. 2 – Replacement Brushes | 6-3 |
| BLADE | 3-18 | Fig. 3 – Hood and Bumper Group | 6-4 |
| TO LEVEL REAR SQUEEGEE (for | | Fig. 4 – Hood and Bumper Group | 6-6 |
| 1465 with serial number below | | Fig. 5 – Main Frame Group | 6-8 |
| 030065, or 1480 with serial | | Fig. 6 – Main Frame Group | 6-9 |
| number below 040161) | 3-19 | Fig. 7 – Side Skirt Support Group | 6-10 |
| TO LEVEL REAR SQUEEGEE (for | | Fig. 8 – Front Shroud Group | 6-12 |
| 1465 serial number 030065 and | | Fig. 9 – Scrub Head Lift Group | 6-14 |
| above, 1480 serial number | | Fig. 10 – Scrub Head Group | 6-16 |
| 040161 and above, and | | Fig. 11 – Tire and Rim Assembly | 6-17 |
| 1490 machines) | 3-19 | Fig. 12 – Dual Drive Group | 6-18 |
| TO ADJUST SQUEEGEE | | Fig. 13 – Solution and Recovery | |
| DEFLECTION (for 1465 with serial | | Tanks Group | 6-20 |
| number below 030065, or 1480 with | | Fig. 14 – Recovery Tank Float Group | 6-22 |
| serial number below 040161) | 3-20 | Fig. 15 – Solution Control Group | 6-24 |
| TO ADJUST SQUEEGEE | | Fig. 16 – Battery Group | 6-26 |
| DEFLECTION (for 1465 serial | | Fig. 17 – Battery Group | 6-28 |
| number 030065 and above, 1480 | | Fig. 18 – Steering Control Group | 6-30 |
| serial number 040161 and above, | | Fig. 19 – Rear Electrical Panel Group ... | 6-32 |
| and 1490 machines) | 3-21 | Fig. 20 – Electrical Controller Group | 6-34 |
| BRAKES AND TIRES | 3-22 | Fig. 21 – Rear Electrical Group | 6-35 |
| PARKING BRAKE | 3-22 | Fig. 22 – Rear Squeegee Link Group | 6-36 |
| TIRES | 3-22 | Fig. 23 – Rear Squeegee Link Group | 6-38 |
| | | Fig. 24 – Rear Squeegee Group | 6-40 |
| | | Fig. 25 – Wire Harness Group | 6-42 |
| | | Fig. 26 – Label Group | 6-44 |

| | Page |
|---|------|
| 1480 MODEL PARTS | 7-1 |
| Fig. 1 – Recommended General Maintenance Items | 7-2 |
| Fig. 2 – Replacement Brushes | 7-3 |
| Fig. 3 – Hood and Bumper Group | 7-4 |
| Fig. 4 – Hood and Bumper Group | 7-6 |
| Fig. 5 – Main Frame Group | 7-8 |
| Fig. 6 – Main Frame Group | 7-9 |
| Fig. 7 – Side Skirt Support Group | 7-10 |
| Fig. 8 – Front Shroud Group | 7-12 |
| Fig. 9 – Scrub Head Lift Group | 7-14 |
| Fig. 10 – Scrub Head Group | 7-16 |
| Fig. 11 – Tire and Rim Assembly | 7-17 |
| Fig. 12 – Dual Drive Group | 7-18 |
| Fig. 13 – Solution And Recovery Tanks Group | 7-20 |
| Fig. 14 – Recovery Tank Float Group | 7-22 |
| Fig. 15 – Solution Control Group | 7-24 |
| Fig. 16 – Battery Group | 7-26 |
| Fig. 17 – Battery Group | 7-28 |
| Fig. 18 – Steering Control Group | 7-30 |
| Fig. 19 – Rear Electrical Panel Group | 7-32 |
| Fig. 20 – Electrical Controller Group | 7-34 |
| Fig. 21 – Rear Electrical Group | 7-35 |
| Fig. 23 – Rear Squeegee Link Group | 7-38 |
| Fig. 24 – Rear Squeegee Group | 7-40 |
| Fig. 25 – Wire Harness Group | 7-42 |
| Fig. 26 – Label Group | 7-44 |
| 1490 MODEL PARTS | 8-1 |
| Fig. 1 – Recommended General Maintenance Items | 8-2 |
| Fig. 2 – Replacement Brushes | 8-3 |
| Fig. 3 – Hood and Bumper Group | 8-4 |
| Fig. 4 – Main Frame Group | 8-6 |
| Fig. 5 – Front Shroud Group | 8-8 |
| Fig. 6 – Scrub Head Lift Group | 8-10 |
| Fig. 7 – Scrub Head Group | 8-12 |
| Fig. 8 – Tire and Rim Assembly | 8-13 |
| Fig. 9 – Dual Drive Group | 8-14 |
| Fig. 10 – Solution and Recovery Tanks Group | 8-16 |
| Fig. 11 – Vacuum Fan Group | 8-18 |
| Fig. 12 – Solution Control Group | 8-20 |
| Fig. 13 – Battery Group | 8-22 |
| Fig. 14 – Steering Control Group | 8-24 |
| Fig. 15 – Rear Electrical Panel Group | 8-26 |
| Fig. 16 – Electrical Controller Group | 8-28 |
| Fig. 17 – Rear Electrical Group | 8-29 |
| Fig. 18 – Rear Squeegee Link Group | 8-30 |
| Fig. 19 – Rear Squeegee Group | 8-32 |
| Fig. 20 – Label Group | 8-33 |
| Fig. 21 – Wire Harness Group | 8-34 |

| | Page |
|---|------|
| OPTIONS | 9-1 |
| Fig. 1 – Heavy Duty Bumper Kit, 1465 | 9-2 |
| Fig. 2 – Heavy Duty Bumper Kit, 1465 | 9-3 |
| Fig. 3 – Heavy Duty Bumper Kit, 1480 | 9-4 |
| Fig. 4 – Heavy Duty Bumper Kit, 1480 | 9-5 |
| Fig. 5 – Heavy Duty Bumper Kit, 1490 | 9-6 |
| Fig. 6 – Demo Group, 1465 | 9-7 |
| Fig. 7 – Demo Group, 1480 | 9-8 |
| Fig. 8 – Demo Group, 1490 | 9-9 |
| Fig. 9 – Vacuum Wand Kit | 9-10 |
| Fig. 10 – Pre-Sweep™ Mounting Group, 1465 | 9-12 |
| Fig. 11 – Pre-Sweep™ Mounting Group, 1480 | 9-13 |
| Fig. 12 – Pre-Sweep™ Drive Group, 1465 | 9-14 |
| Fig. 13 – Pre-Sweep™ Drive Group, 1480 | 9-16 |
| Fig. 14 – Pre-Sweep™ Frame Group, 1465 | 9-18 |
| Fig. 15 – Pre-Sweep™ Frame Group, 1480 | 9-20 |
| Fig. 16 – Extended Scrub Group, 1465 | 9-22 |
| Fig. 17 – Extended Scrub Group, 1480 | 9-24 |
| Fig. 18 – Extended Scrub Group, 1490 | 9-26 |
| Fig. 19 – Wheel Cover Group | 9-28 |
| Fig. 20 – Foam Filled Tire Group | 9-29 |
| Fig. 21 – Dual Parking Brake Group | 9-30 |
| Fig. 22 – GS Group, 1465 | 9-32 |
| Fig. 23 – GS Group, 1480 | 9-34 |
| Fig. 24 – Battery Charger Group, 60 Hz (220 Ah batteries) | 9-36 |
| Fig. 25 – Battery Charger Group, 50 Hz (220 Ah batteries) | 9-37 |
| Fig. 26 – Battery Charger Group, 40A, 36V, 50 Hz (305 Ah batteries) | 9-38 |
| Fig. 27 – Battery Charger Group, 36A, 36V, 115V (305 Ah batteries) | 9-39 |
| Fig. 28 – Battery Charger Group, 60 Hz (220 Ah batteries) | 9-40 |
| Fig. 29 – Battery Charger Group, 50 Hz, 230V, (220 Ah batteries) | 9-41 |
| Fig. 30 – Battery Charger Group, 50 Hz, 245V, (220 Ah batteries) | 9-41 |
| Fig. 31 – Battery Charger Group, 60 Hz (305 Ah batteries) | 9-42 |
| Fig. 32 – Battery Charger Group, 50 Hz (305 Ah batteries) | 9-43 |
| Fig. 33 – Heavy Duty Battery Kit, Wet, 1480 | 9-44 |
| Fig. 34 – Heavy Duty Battery Kit, Dry, 1480 | 9-45 |
| Fig. 35 – Battery Tray Group, 1465 | 9-46 |
| Fig. 36 – Battery Tray Group, 1480, 1490 | 9-47 |

GENERAL INFORMATION

| | Page |
|--|------|
| Fig. 37 – Heavy Duty Battery Tray Group, 1480, 1490 | 9-48 |
| Fig. 38 – Power Wand Hose Assembly .. | 9-49 |
| Fig. 39 – Power Wand Assembly | 9-50 |
| Fig. 40 – Power Wand Pump and Electrical Group | 9-52 |
| Fig. 41 – Power Wand Mount Group | 9-54 |
| | |
| BREAKDOWNS | 10-1 |
| Fig. 1 – Electric Motor Breakdown, 0914 | 10-2 |
| Fig. 2 – Electric Motor Breakdown, 28386 | 10-4 |
| Fig. 3 – Electric Motor Breakdown, 04922 | 10-6 |
| Fig. 4 – Electric Motor Breakdown, 04656 | 10-7 |
| Fig. 5 – Water Pump Breakdown, 10916 | 10-8 |
| Fig. 6 – Water Pump Breakdown, 65590 | 10-9 |
| | |
| CROSS REFERENCE | 11-1 |

CONTENTS

| | Page |
|--|------|
| MACHINE SPECIFICATIONS – 1465 | 1-3 |
| POWER TYPE | 1-3 |
| POWER TRAIN | 1-3 |
| STEERING | 1-3 |
| BRAKING SYSTEM | 1-3 |
| SUSPENSION SYSTEM | 1-3 |
| SYSTEM FLUID CAPACITIES | 1-3 |
| GENERAL MACHINE DIMENSIONS – CAPACITIES | 1-3 |
| MACHINE WEIGHTS | 1-3 |
| GENERAL MACHINE PERFORMANCE . | 1-3 |
| MACHINE DIMENSIONS – 1465 | 1-4 |
| MACHINE SPECIFICATIONS – 1480 | 1-5 |
| POWER TYPE | 1-5 |
| POWER TRAIN | 1-5 |
| STEERING | 1-5 |
| BRAKING SYSTEM | 1-5 |
| SUSPENSION SYSTEM | 1-5 |
| SYSTEM FLUID CAPACITIES | 1-5 |
| GENERAL MACHINE DIMENSIONS – CAPACITIES | 1-5 |
| MACHINE WEIGHTS | 1-5 |
| GENERAL MACHINE PERFORMANCE . | 1-5 |
| MACHINE DIMENSIONS – 1480 | 1-6 |
| MACHINE SPECIFICATIONS – 1490 | 1-7 |
| POWER TYPE | 1-7 |
| POWER TRAIN | 1-7 |
| STEERING | 1-7 |
| BRAKING SYSTEM | 1-7 |
| SUSPENSION SYSTEM | 1-7 |
| SYSTEM FLUID CAPACITIES | 1-7 |
| GENERAL MACHINE DIMENSIONS – CAPACITIES | 1-7 |
| MACHINE WEIGHTS | 1-7 |
| GENERAL MACHINE PERFORMANCE . | 1-7 |
| MACHINE DIMENSIONS – 1490 | 1-8 |

MACHINE SPECIFICATIONS – 1465**POWER TYPE**

Electric propelling motors, (2) – nominal voltage
36 VDC, 0.20 hp (0.15 kW) @ 250 rpm
Electric vacuum fan motor – nominal voltage
36 VDC, 0.85 hp (0.63 kW) @ 14000 rpm
Electric scrub brush motors, (2)
nominal voltage 36 VDC,
1.20 hp (0.89 kW) @ 250 rpm maximum
0.80 hp (0.60 kW) @ 320 rpm continuous
Electric Pre-Sweep motor (option) –
nominal voltage 36 VDC, 0.20 hp (0.15 kW)
@ 250 rpm

Batteries (6) – 6 V, 220 A/h @ 20 hour rate
Battery charger options – 36 VDC 25 A,
115 VAC, 60 hz
36 VDC 25 A, 230 VAC, 50 hz

POWER TRAIN

Propelling – electric motor direct driven

Scrub brushes – electric motor direct driven

Vacuum fan – electric motor direct driven

Pre-Sweep brush (option) – electric motor belt
driven

STEERING

Type – dual motor driven

BRAKING SYSTEM

Parking brakes (option) – disc type, cable
actuated

SUSPENSION SYSTEM

Front (2) – 4.10/3.50–6 pneumatic tires
Rear (2) – 5 in (130 mm) solid casters

SYSTEM FLUID CAPACITIES

Solution tank capacity – 22.1 gal (83.7 L)
Recovery tank capacity – 27 gal (102.2 L)

**GENERAL MACHINE DIMENSIONS –
CAPACITIES**

Length – 63.5 in (1615 mm)
Length with Pre-Sweep™ – 82.4 in (2095 mm)

Width – 27.9 in (710 mm)
Width with squeegee – 31.9 in (810 mm)

Height – 44.3 in (1125 mm)

Track, front – 20.38 in (520 mm)
Track, rear – 17.06 in (435 mm)

Wheel base – 17.68 in (450 mm)

Scrub brush diameter – 14 in (355 mm)

Pre-Sweep™ brush (option) diameter – 5.5 in
(140 mm)
Pre-Sweep™ brush (option) length – 20 in
(510 mm)

Scrubbing path width – 26 in (650 mm)

Pre-Sweep™ hopper capacity – 1 cu ft (0.03 m³)

Rear squeegee path width – 31.9 in (810 mm)

MACHINE WEIGHTS

GVWR – 1300 lb (590 kg)

GENERAL MACHINE PERFORMANCE

Maximum forward speed – 2.8 mph (4.5 km/h)
Maximum reverse speed – 1.5 mph (2.4 km/h)

Aisle turnaround width – 64.75 in (1645 mm)
Aisle turnaround width with Pre-Sweep™ –
82.00 in (2080 mm)

Maximum rated ramp climb angle – 6°
Maximum rated ramp descent angle – 6°

SPECIFICATIONS

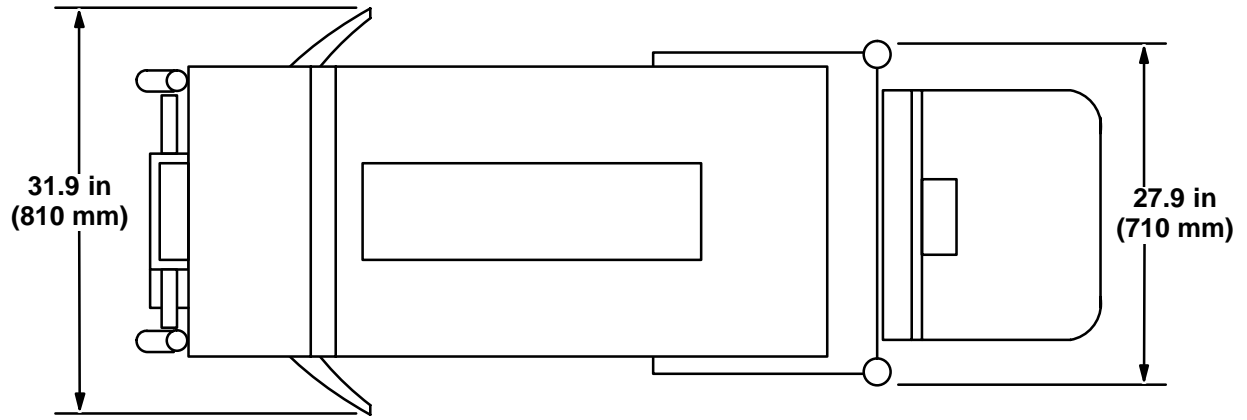

TOP VIEW

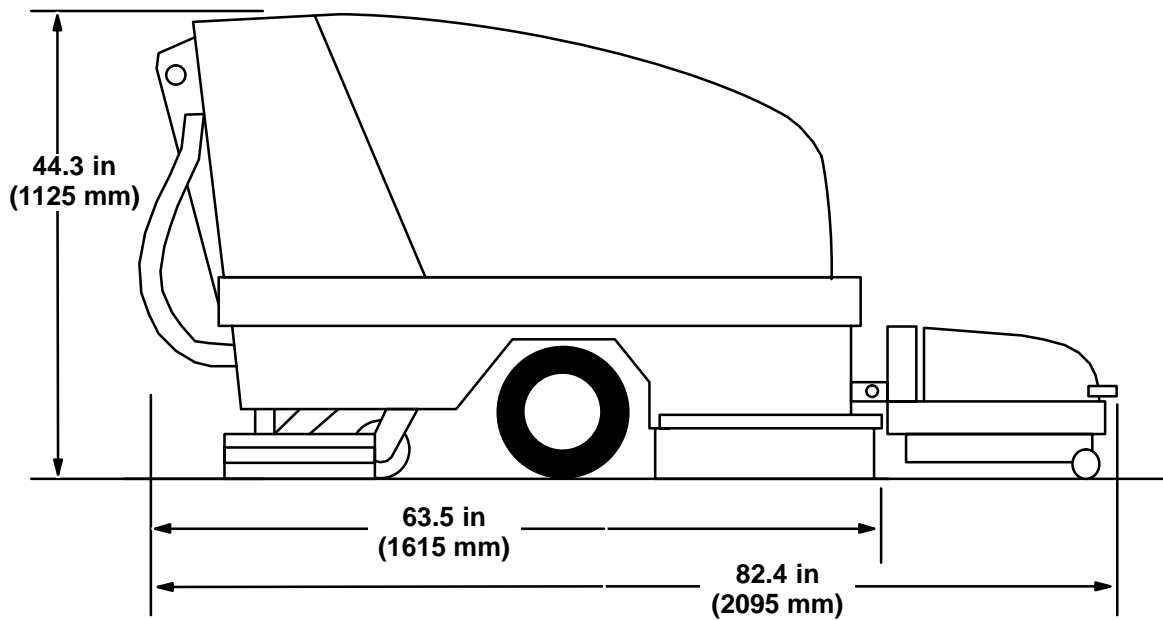

SIDE VIEW

MACHINE DIMENSIONS – 1465

04340

MACHINE SPECIFICATIONS – 1480**POWER TYPE**

Electric propelling motors, (2) – nominal voltage
36 VDC, 0.20 hp (0.15 kW) @ 250 rpm
Electric vacuum fan motor – nominal voltage
36 VDC, 0.85 hp (0.63 kW) @ 14000 rpm
Electric scrub brush motors, (2)
nominal voltage 36 VDC,
1.20 hp (0.89 kW) @ 250 rpm maximum
0.80 hp (0.60 kW) @ 320 rpm continuous
Electric Pre-Sweep motor (option) –
nominal voltage 36 VDC, 0.20 hp (0.15 kW)
@ 250 rpm

Batteries (6) – 6 V, 220 A/h @ 20 hour rate
Batteries (heavy duty option) (6) – 6 V,
305 A/h @ 20 hour rate
Battery charger options – 36 VDC 20 A,
115 VAC, 60 hz
36 VDC 20 A, 230 VAC, 50 hz

POWER TRAIN

Propelling – electric motor direct driven
Scrub brushes – electric motor direct driven
Vacuum fan – electric motor direct driven
Pre-Sweep brush (option) – electric motor belt
driven

STEERING

Type – dual motor driven

BRAKING SYSTEM

Parking brakes (option) – disc type, cable
actuated

SUSPENSION SYSTEM

Front (2) – 4.10/3.50–6 pneumatic tires
Rear (2) – 5 in (130 mm) solid casters

SYSTEM FLUID CAPACITIES

Solution tank capacity – 27.5 gal (104.1 L)
Recovery tank capacity – 31 gal (117.3 L)

**GENERAL MACHINE DIMENSIONS –
CAPACITIES**

Length – 66.5 in (1690 mm)
Length with Pre-Sweep™ – 86.1 in (2190 mm)

Width – 35.1 in (890 mm)
Width with squeegee – 37.6 in (955 mm)

Height – 44.3 in (1125 mm)

Track, front – 20.38 in (520 mm)
Track, rear – 17.06 in (435 mm)

Wheel base – 17.68 in (450 mm)

Scrub brush diameter – 16 in (405 mm)

Pre-Sweep™ brush (option) diameter – 5.5 in
(140 mm)

Pre-Sweep™ brush (option) length – 26 in
(660 mm)

Scrubbing path width – 32 in (800 mm)

Pre-Sweep™ hopper capacity – 1.25 cu ft
(0.04 m³)

Rear squeegee path width – 37.5 in (955 mm)

MACHINE WEIGHTS

GVWR – 1610 lb (730 kg)

GENERAL MACHINE PERFORMANCE

Maximum forward speed – 2.8 mph (4.5 km/h)
Maximum reverse speed – 1.5 mph (2.4 km/h)

Aisle turnaround width – 68.8 in (1750 mm)
Aisle turnaround width with Pre-Sweep™ – 86.4
in (2200 mm)

Maximum rated ramp climb angle – 6°
Maximum rated ramp descent angle – 6°

SPECIFICATIONS

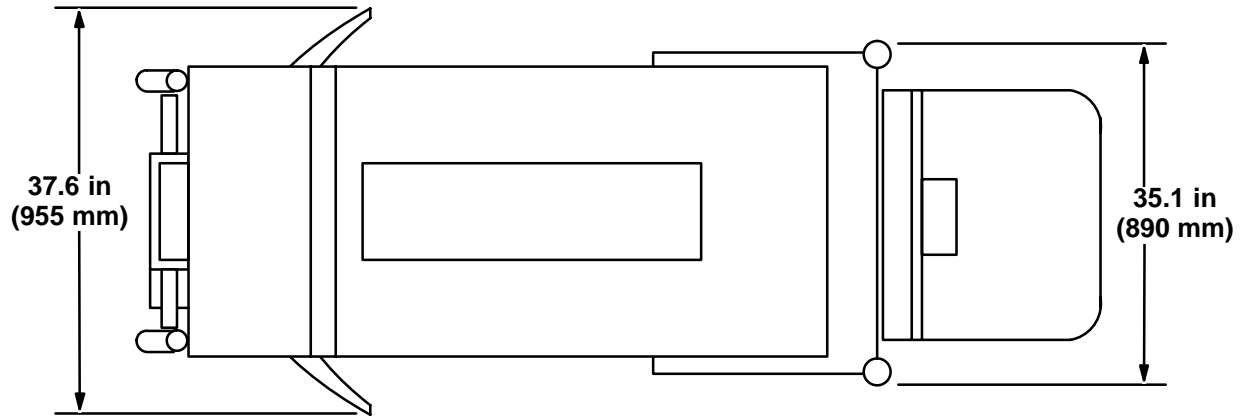

TOP VIEW

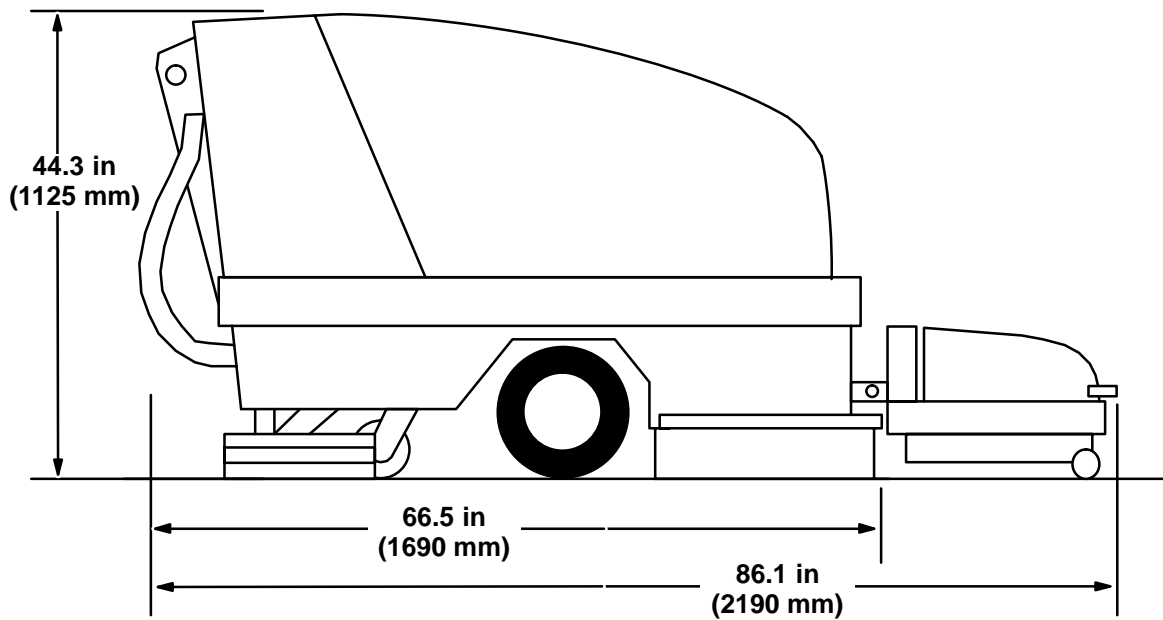

SIDE VIEW

MACHINE DIMENSIONS – 1480

04340

MACHINE SPECIFICATIONS – 1490**POWER TYPE**

Electric propelling motors, (2) – nominal voltage
36 VDC, 0.20 hp (0.15 kW) @ 250 rpm
Electric vacuum fan motor – nominal voltage
36 VDC, 1.25 hp (0.93 kW) @ 10500 rpm
Electric scrub brush motors, (2)
nominal voltage 36 VDC,
1.20 hp (0.89 kW) @ 250 rpm maximum
0.80 hp (0.60 kW) @ 320 rpm continuous

Batteries (6) – 6 V, 220 A/h @ 20 hour rate
Batteries (heavy duty option) (6) – 6 V,
305 A/h @ 20 hour rate
Battery charger options – 30 VDC 30 A,
115 VAC, 60 hz
36 VDC 30 A, 230 VAC, 50

POWER TRAIN

Propelling – electric motor direct driven

Scrub brushes – electric motor direct driven

Vacuum fan – electric motor direct driven

STEERING

Type – dual motor driven

BRAKING SYSTEM

Parking brakes (option) – disc type, cable
actuated

SUSPENSION SYSTEM

Front (2) – 4.10/3.50–6 pneumatic tires
Rear (2) – 5 in (130 mm) solid casters

SYSTEM FLUID CAPACITIES

Solution tank capacity – 27.5 gal (104.1 L)
Recovery tank capacity – 31 gal (117.3 L)

**GENERAL MACHINE DIMENSIONS –
CAPACITIES**

Length – 67.3 in (1710 mm)

Width – 39.0 in (990 mm)
Width with squeegee – 42.8 in (1090 mm)

Height – 44.3 in (1125 mm)

Track, front – 20.38 in (520 mm)
Track, rear – 17.06 in (435 mm)

Wheel base – 17.68 in (450 mm)

Scrub brush diameter – 18 in (455 mm)

Scrubbing path width – 36 in (914 mm)

Rear squeegee path width – 42.8 in (1090 mm)

MACHINE WEIGHTS

GVWR – 1648 lb (747 kg)

GENERAL MACHINE PERFORMANCE

Maximum forward speed – 2.8 mph (4.5 km/h)
Maximum reverse speed – 1.5 mph (2.4 km/h)

Aisle turnaround width – 70.9 in (1801 mm)

Maximum rated ramp climb angle – 6°
Maximum rated ramp descent angle – 6°

SPECIFICATIONS

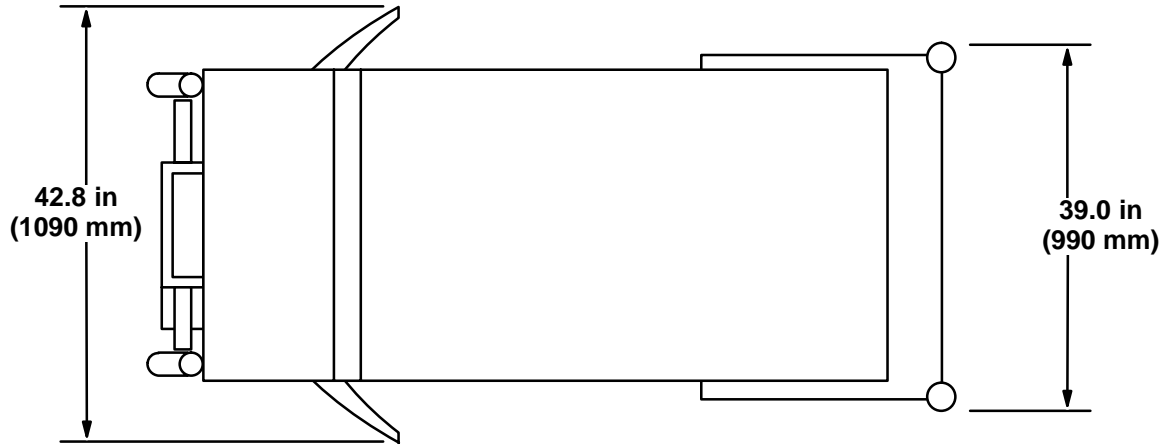

TOP VIEW

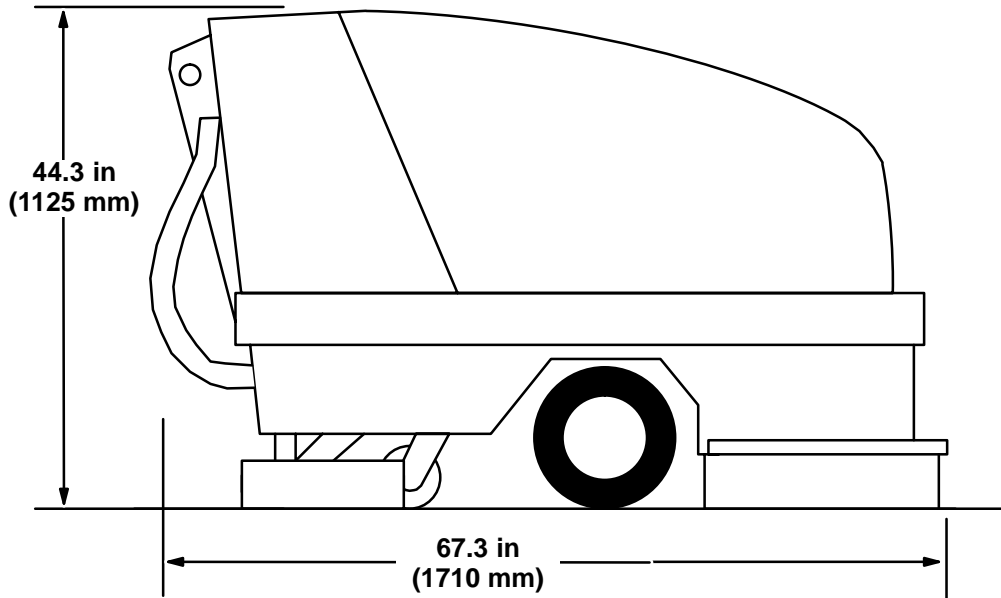

SIDE VIEW

MACHINE DIMENSIONS – 1490

06311

SECTION 2

CONTENTS

| | Page | | Page |
|----------------------------------|------|---------------------------------|------|
| PREPARATION FOR OPERATION | 2-3 | OPTIONS OPERATION | 2-16 |
| AFTER UNCRATING AND BEFORE | | VACUUM WAND ATTACHMENT | 2-16 |
| OPERATING MACHINE: | 2-3 | TO OPERATE VACUUM WAND | |
| OPERATION OF CONTROLS | 2-4 | ATTACHMENT | 2-16 |
| MACHINE COMPONENTS | 2-4 | POWER WAND | 2-17 |
| HOW IT WORKS | 2-5 | TO OPERATE THE POWER WAND .. | 2-17 |
| INSTRUMENT PANEL SYMBOLS | 2-5 | PRE-SWEEP™ | 2-19 |
| CONTROLS AND INSTRUMENTS | 2-6 | TO REMOVE PRE-SWEEP™ | 2-19 |
| STEERING HANDLES | 2-7 | TO MOUNT THE PRE-SWEEP™ | 2-20 |
| RECOVERY TANK FULL INDICATOR .. | 2-7 | TRANSPORTING MACHINE | 2-22 |
| BRUSH CIRCUIT BREAKER INDICATOR | 2-7 | PUSHING OR TOWING MACHINE | 2-22 |
| HOUR METER | 2-7 | MACHINE JACKING | 2-22 |
| KEY-OPERATED ON-OFF SWITCH | 2-7 | TO JACK UP MACHINE | 2-22 |
| BATTERY DISCHARGE INDICATOR ... | 2-7 | MACHINE TIE-DOWNS | 2-23 |
| ES™ SWITCH | 2-7 | MACHINE STORAGE | 2-24 |
| SQUEEGEE SWITCH | 2-8 | STORING MACHINE | 2-24 |
| BRUSH PRESSURE SWITCH AND | | | |
| INDICATOR | 2-8 | | |
| SUPER SCRUB SWITCH | 2-8 | | |
| SCRUB BRUSH SWITCH | 2-8 | | |
| SOLUTION LEVER | 2-8 | | |
| AUTO STOP SWITCH | 2-9 | | |
| POWER WAND | 2-9 | | |
| PRE-SWEEP™ BRUSH HANDLE | 2-9 | | |
| PARKING BRAKE LEVER | 2-9 | | |
| CIRCUIT BREAKERS | 2-9 | | |
| MACHINE OPERATION | 2-10 | | |
| NORMAL SCRUBBING OPERATION ... | 2-10 | | |
| PRE-START CHECKLIST | 2-10 | | |
| TO START MACHINE | 2-10 | | |
| TO FILL SOLUTION TANK | 2-10 | | |
| TO SCRUB | 2-11 | | |
| TO DRAIN AND CLEAN RECOVERY | | | |
| TANK | 2-11 | | |
| POST OPERATION CHECKLIST - | | | |
| MACHINE ON | 2-13 | | |
| TO STOP MACHINE | 2-13 | | |
| POST OPERATION CHECKLIST - | | | |
| MACHINE OFF | 2-14 | | |
| DOUBLE SCRUBBING OPERATION ... | 2-14 | | |
| OPERATION ON GRADES | 2-14 | | |
| MACHINE TROUBLESHOOTING | 2-15 | | |

PREPARATION FOR OPERATION

AFTER UNCRATING AND BEFORE OPERATING MACHINE:

1. Check the machine for shipping damage.
2. Read this manual carefully before operating or servicing the machine.

FOR SAFETY: Do Not Operate The Machine Unless Operation Manual Is Read And Understood.

3. Lift open the machine hood, then tilt open the battery cover.

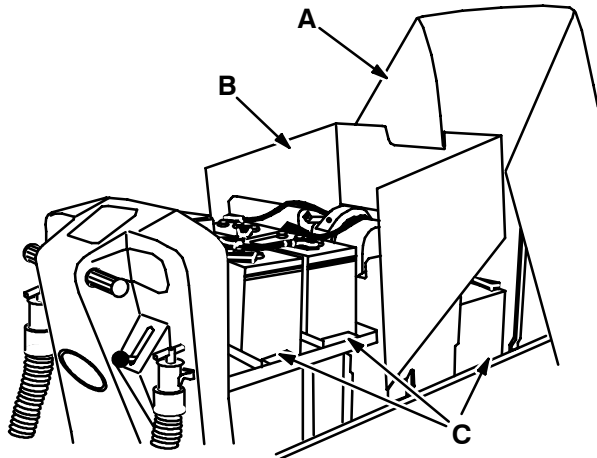

OPEN BATTERY COVERS

04342

- A. Front Cover**
- B. Rear Cover**
- C. Batteries**

4. Check the batteries electrolyte level as described in *BATTERIES* in the *MAINTENANCE* section.

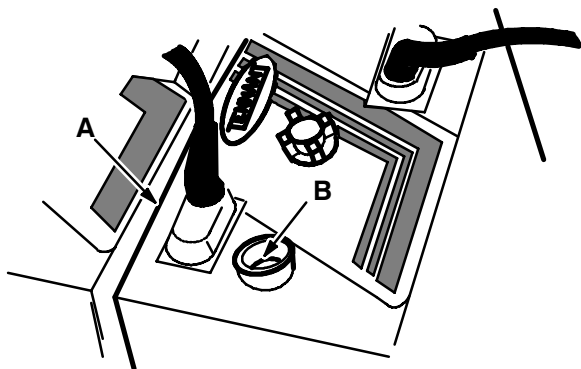

CHECKING BATTERY ELECTROLYTE LEVEL

00879

- A. Battery**
- B. Electrolyte Indicator Ring**

FOR SAFETY: When Servicing Machine, Avoid Contact With Battery Acid.

5. Check the battery specific gravity to determine the state of charge as described in *BATTERIES* in the *MAINTENANCE* section. Charge the batteries if necessary.
6. Connect the battery connector to the machine connector.

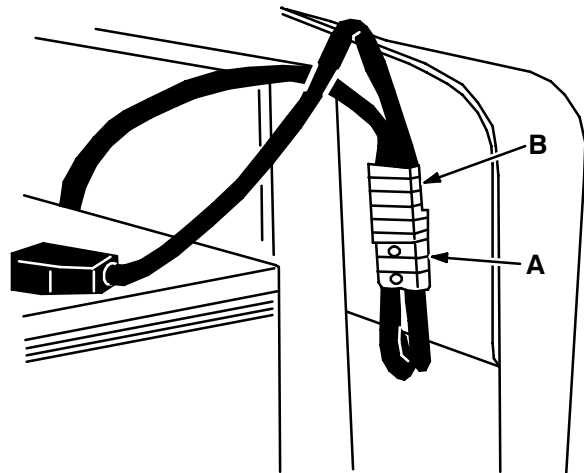

04343

CONNECTING BATTERY CONNECTORS

- A. Machine Connector**
- B. Battery Connector**

7. Install scrub brushes as described in *SCRUB BRUSHES* in the *MAINTENANCE* section.
8. Pre-Sweep™ machines: Install Pre-Sweep™ assembly as described in *TO MOUNT PRE-SWEEP™*.

OPERATION OF CONTROLS

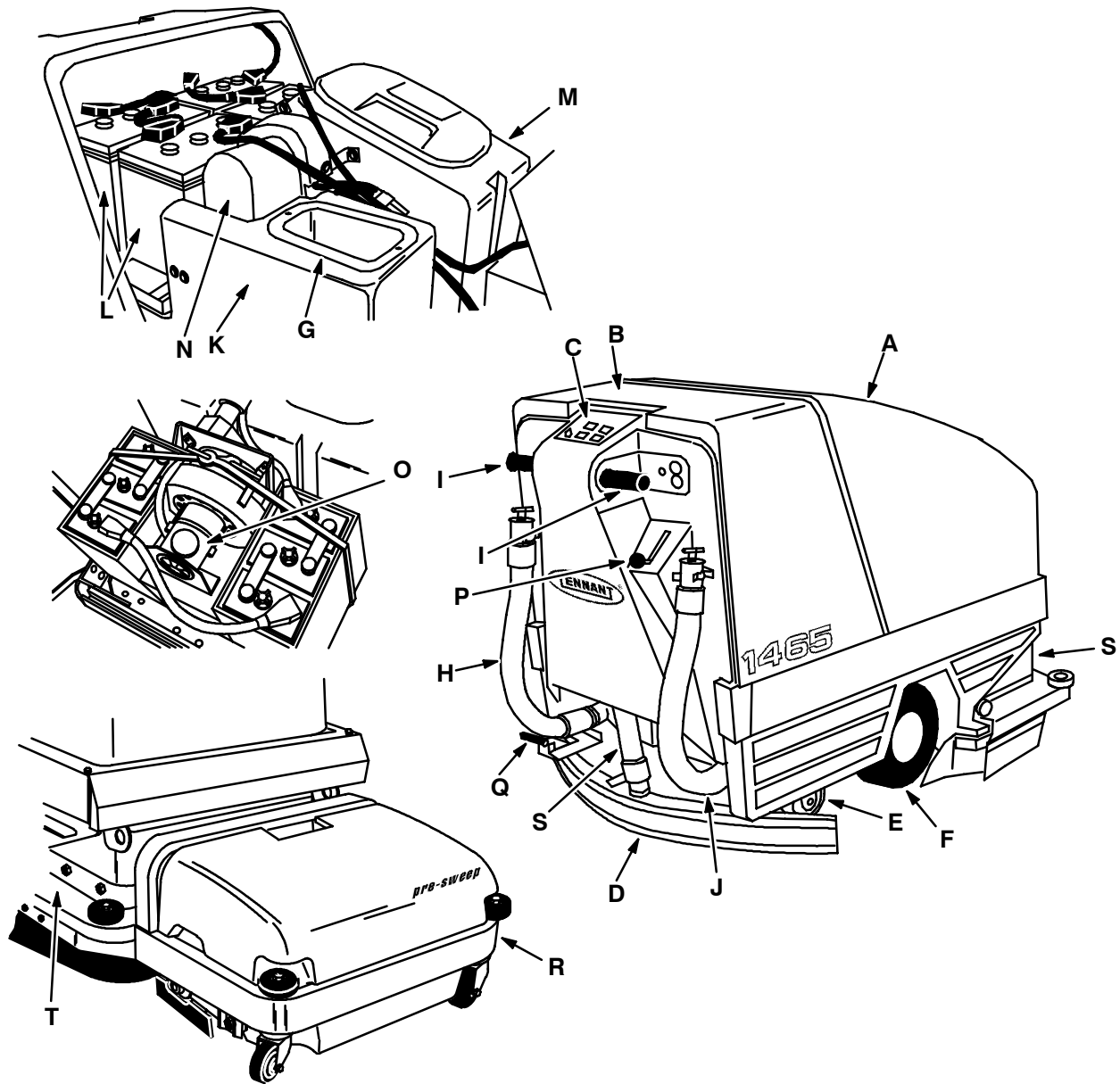

04378
04344
04345
06449

MACHINE COMPONENTS

- | | |
|-----------------------------|---------------------------|
| A. Machine Hood | K. Solution Tank |
| B. Rear Cover | L. Batteries |
| C. Control Panel | M. Recovery Tank |
| D. Squeegee | N. Vacuum Fan (1465/1480) |
| E. Rear Caster | O. Vacuum Fan (1490) |
| F. Front Wheel | P. Solution Lever |
| G. Soap Basket | Q. Parking Brake Lever |
| H. Recovery Tank Drain Hose | R. Pre-Sweep™ |
| I. Steering Handle | S. Squeegee Suction Hose |
| J. Solution Tank Drain Hose | T. Scrub Head Cover |

HOW IT WORKS

The Model 1465, 1480, and 1490 are walk-behind scrubbers.

The machines are propelled by a dual electric motor system, and are equipped with power steering. Twisting the steering handles moves the machine forward or backward. Pulling the steering handle nearest the direction of travel steers the machine.

The main scrubbing components include a solution tank, two disk-type brushes, a rear squeegee, a vacuum fan, and a recovery tank.

Water and detergent solution flows from the solution tank through the water control valve to the scrub brushes. The rotating scrub brushes scrub the floor. As the machine moves forward, the rear squeegee collects the dirty solution and channels it into the vacuum of the squeegee pickup hose. The pickup hose deposits the dirty solution in the recovery tank.

Machines with the ES™ option filter the dirty solution in the recovery tank and return it to the solution tank.

INSTRUMENT PANEL SYMBOLS

The symbols are used to identify controls and displays on the machine:



Recovery Tank Full



Scrub Brush



Battery



ES™



Hourmeter



Squeegee down



Key Switch



Scrub Brush Down



Scrub Brush On



Cleaning Solution



Variable Rate

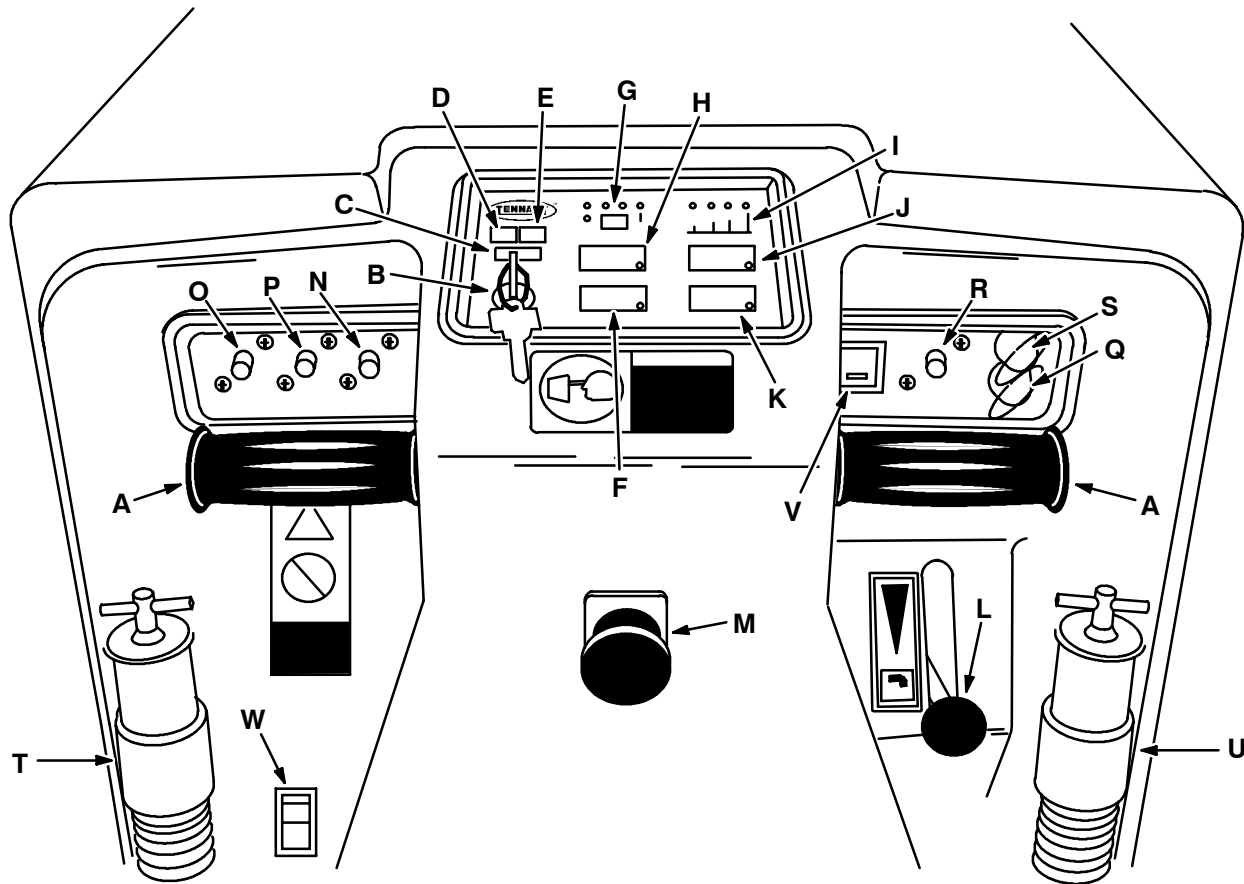

04348

CONTROLS AND INSTRUMENTS

- | | |
|------------------------------------|------------------------------|
| A. Steering Handles | L. Solution Lever |
| B. Key-Operated On-Off Switch | M. Auto Stop Switch |
| C. Hour Meter | N. Circuit Breaker 1 |
| D. Recovery Tank Full Indicator | O. Circuit Breaker 2 |
| E. Brush Circuit Breaker Indicator | P. Circuit Breaker 3 |
| F. Squeegee Switch | Q. Circuit Breaker 4 |
| G. Battery Discharge Indicator | R. Circuit Breaker 5 |
| H. ES™ Switch | S. Circuit Breaker 6 |
| I. Brush Pressure Indicator | T. Recovery Tank Drain Hose |
| J. Brush Pressure Switch | U. Solution Tank Drain Hose |
| K. Scrub Brush Switch | V. Super Scrub Switch (1490) |
| | W. Power Wand Switch |

STEERING HANDLES

The steering handles control machine speed and direction through a solid state switching circuit.

To move the machine forward, twist the handles forward. Twisting the handles a little will move the machine slowly. Twisting the handles all of the way forward will move the machine at top speed.

To move the machine backward, twist the handles backward.

To stop the machine, release the handles.

To turn the machine, pull the handle nearest the direction of the turn. Pull the right handle to turn right. Pull the left handle to turn left.

RECOVERY TANK FULL INDICATOR

The recovery tank full indicator  glows when the recovery tank is full. The vacuum fan stops and the squeegee lifts when the indicator glows.

BRUSH CIRCUIT BREAKER INDICATOR

The brush circuit breaker indicator  glows when one or both of the two brush motor circuit breakers have tripped. The circuit breaker(s) have to be reset before resuming scrubbing.

HOOR METER

The hour meter  records the number of hours the machine has operated. This information is useful in determining when to service the machine.

KEY-OPERATED ON-OFF SWITCH

The key-operated on-off switch  controls all machine power except power to the vacuum fan. To allow the machine to operate, turn the key clockwise. The machine has a six second startup delay so it can run through a system check. After the delay the machine is ready to operate.

To turn off the machine, turn the key-operated on-off switch counter-clockwise.

BATTERY DISCHARGE INDICATOR

The battery discharge indicator  indicates the charge level of the batteries. It displays the charge level when the brushes are operating.

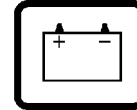
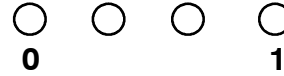

BATTERY DISCHARGE INDICATOR

04360

The display should be on the 1 mark of the gauge when the batteries are fully charged. As the batteries discharge, the display will move near the 0 mark. For best battery life, the batteries should be recharged when the display nears the 0 mark. If the light near the 0 mark starts to blink, the batteries are fully discharged. At this point, the brushes will automatically raise to limit current draw and to provide a warning. Further operation of the machine could damage the machine or batteries.

When the machine is left overnight with less than a full charge, the display may indicate a full charge. It is reading the surface charge level - not the true charge level. After running the machine a few minutes, the gauge will give the correct charge level.

NOTE: Do not charge the batteries more often than is necessary. This will prolong the life of the batteries. Do not allow the batteries to become fully discharged as this will also damage the batteries. See BATTERIES in the MAINTENANCE section.

ES™ SWITCH

The ES™ switch  controls the solution recycling system on machines with the ES™ option.

The machine will start with the ES™ system on. The ES™ pump may not start right away. It will start as the tank fills up.

To stop the system, press the ES™ switch again.

OPERATION

SQUEEGEE SWITCH

The squeegee switch , along with the steering handles, control the position of the rear squeegee and the vacuum fan.

To start the vacuum fan and lower the rear squeegee, press the squeegee switch. When the steering handles are twisted backward, the squeegee lifts. This prevents the rear squeegee from being damaged when backing machine. The squeegee will lower when the steering handles are twisted forward again.

To stop the vacuum fan and raise the rear squeegee, press the squeegee switch again.

BRUSH PRESSURE SWITCH AND INDICATOR

The brush pressure switch  controls how aggressive the brushes are on the floor. The brush pressure indicator shows the pressure selection.

The brush pressure switch has four positions. Under normal conditions, the brush pressure should be set in the light zone. Under heavy grime conditions, the brush pressure should be set in the heavy zones. Travel speed and floor conditions will affect the scrubbing performance.

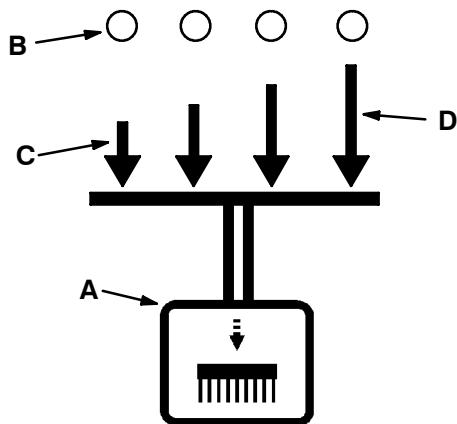

04361

BRUSH PRESSURE SWITCH AND INDICATOR

- A. Brush Pressure Switch
- B. Brush Pressure Indicator
- C. Light Pressure Zone
- D. Heavy Pressure Zone

To change brush pressure, touch the brush pressure switch. Each time you touch the switch it will increase brush pressure until it reaches the maximum setting. Then it will return to the minimum setting as shown on the pressure indicator.

SUPER SCRUB SWITCH

The super scrub switch allows spot cleaning of heavy grime buildup by putting the brush pressure into the heavy setting for approximately 30 seconds when activated. After the 30 seconds, the brush pressure will revert back to the previous setting.

SCRUB BRUSH SWITCH

The scrub brush switch  controls scrub brush position and rotation.

To lower and start the brushes turning, press the scrub brush switch. To raise and stop the brushes, press the scrub brush switch again.

NOTE: On the 1490 machines, the propelling control must be activated to lower and start the brushes. When the machine is stopped, the brushes will automatically stop and raise.

SOLUTION LEVER

The solution lever  controls the flow of solution to the floor.

To start solution flow, move the solution lever up slightly. To increase to full flow, move the lever all the way up.

To stop solution flow, move the lever all of the way down.

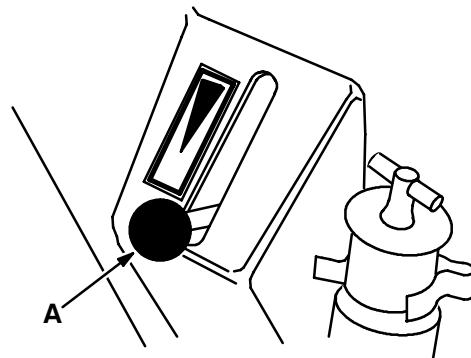

SOLUTION LEVER

- A. Solution Lever

04359

AUTO STOP SWITCH

The auto stop switch cuts all power to the machine.

To stop all power to the machine, push the auto stop switch. To start the machine again, turn the key-operated on-off switch clockwise to turn the machine off. Then turn the key-operated on-off switch all the way clockwise and release in order to turn the machine back on.

POWER WAND SWITCH

The power wand switch controls the solution to the power wand option.

To start the solution flow to the power wand, press the top or **ON** position of the switch. To stop the solution flow to the power wand, press the bottom or **OFF** position of the switch.

PRE-SWEEP™ BRUSH HANDLE

The Pre-Sweep™ brush handle lowers and raises the Pre-Sweep™ brush. When the brush is lowered, it will rotate when the scrub brushes are operating. When the brush is in the raised position it will not rotate. The machine can be operated with the Pre-Sweep™ assembly mounted to the machine even if the brush in the raised position.

To lower the brush, pull up and to the right and lower the handle. To raise the brush, pull up on the handle and over to the left until the handle catches.

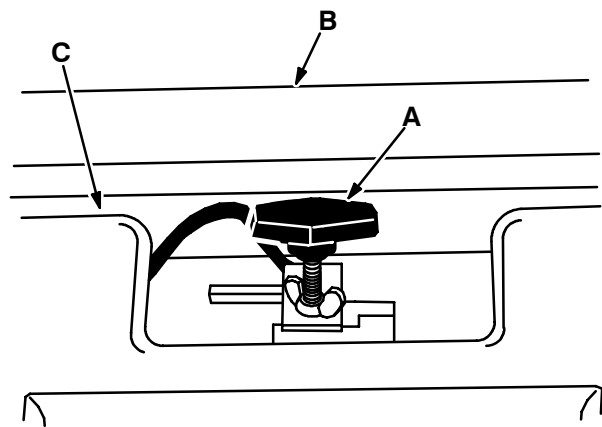

PRE-SWEEP™ BRUSH HANDLE

- A. Pre-Sweep™ Brush Handle**
- B. Pre-Sweep™ Frame**
- C. Pre-Sweep™ Hopper**

PARKING BRAKE LEVER

The parking brake lever is present on machines with the parking brake option. It operates the front wheel brakes.

To set the parking brake, step on the lever.

To release the parking brake, pull the lever up with the toe of your shoe.

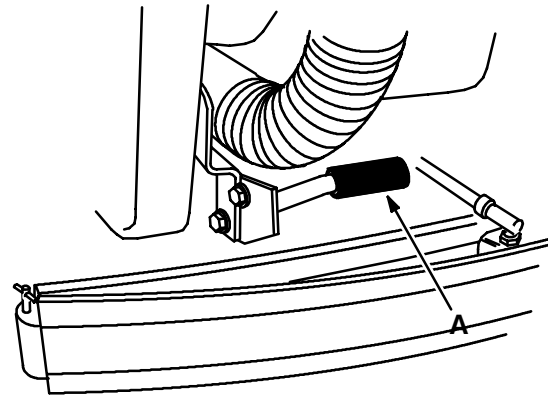

PARKING BRAKE

- A. Parking Brake Lever**

04375

CIRCUIT BREAKERS

Circuit breakers are resettable circuit protection devices designed to stop the flow of current in the event of a circuit overload. Once tripped, circuit breakers must be manually reset by pressing the reset button. Circuit breakers with a rating higher than 10 Amps must be allowed to cool for about two minutes before resetting. If the overload which caused the circuit breaker to trip is still present in the circuit, the circuit breaker will continue to stop current flow until the overload is corrected.

The circuit breakers are located on either side of the control panel.

The following chart shows the various circuit breakers, and the electrical components they protect.

| PROTECTIVE DEVICE PROTECTED | RATING | CIRCUIT |
|-----------------------------|--------|---------------------------|
| CB-1 | 20 A | Vac fan motor (1465/1480) |
| CB-1 | 35 A | Vac fan motor (1490) |
| CB-2 | 25 A | Left scrub brush motor |
| CB-3 | 25 A | Right scrub brush motor |
| CB-4 | 10 A | Pre-Sweep™ |
| CB-5 | 25 A | Propelling |
| CB-6 | 5 A | Control Panel |

MACHINE OPERATION

NORMAL SCRUBBING OPERATION

A normal scrubbing operation consists of eight typical operations: pre-start checklist, starting machine, filling solution tank, scrubbing, draining and cleaning recovery tank, post operation checklist - machine on, stopping machine, and post operation checklist - machine off.

PRE-START CHECKLIST lists things to check before starting the machine.

TO START MACHINE lists the steps required to start the machine.

TO FILL SOLUTION TANK lists the steps required to fill the solution tank.

TO SCRUB lists things to keep in mind before and during the scrubbing operation.

TO DRAIN AND CLEAN RECOVERY TANK lists the steps required to empty and clean the recovery tank.

POST OPERATION CHECKLIST - MACHINE ON lists things to check before stopping the machine motor.

TO STOP MACHINE lists the steps required to stop the machine.

POST OPERATION CHECKLIST - MACHINE OFF lists things to check after stopping the machine motor.

PRE-START CHECKLIST

Check under the machine for leaks.

Check the controls for proper operation.

Check the service records to determine service requirements.

TO START MACHINE

1. Turn the key-operated on-off switch clockwise to turn the machine on.
2. Release the machine parking brake if so equipped.
3. Drive the machine to the solution filling site.

TO FILL SOLUTION TANK

1. Turn off the machine and set the machine parking brake, if equipped.

FOR SAFETY: Before Leaving Or Servicing Machine; Stop On Level Surface, Set Parking Brake (If Equipped), And Turn Off Machine And Remove Key.

2. Pull the solution lever all the way down to stop solution flow.
3. Lift open the machine hood.

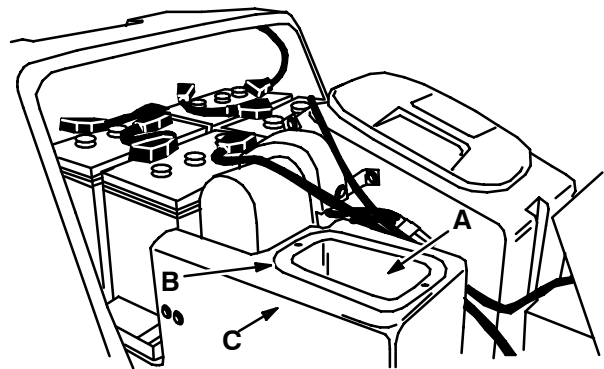

SOLUTION TANK

- A. Fill Opening**
- B. Soap Basket**
- C. Solution Tank**

4. Pour the required amount of detergent into the tank or soap basket. Fill the solution tank with water to 1 in (25 mm) below the tank opening. The water must not be hotter than 130° F (54° C) or tank damage may occur.

ES™ machines: Fill the recovery tank half full with water.

NOTE: Floor conditions, water condition, amount of soilage, type of soilage, brush action, and squeegee action all play an important role in determining the type and the concentration of detergent to be used. For specific recommendations, call your Tennant Company representative.

! WARNING: Flammable Materials Can Cause An Explosion Or Fire. Do Not Use Flammable Materials In Tank(s).

5. Close the machine hood.

TO SCRUB

Plan the scrubbing in advance. Try to arrange long runs with minimum stopping and starting. Do an entire floor or section at one time.

Pick up oversize debris before scrubbing. Remove bulky debris from aisles before scrubbing. Pick up pieces of wire, twine, string, etc., which could become entangled in the scrub brushes.

Try to scrub as straight a path as possible. Avoid bumping into posts or scraping the sides of the machine. When scrubbing dead end aisles, start at the end and scrub your way out of them. Allow a few inches overlap of brush paths.

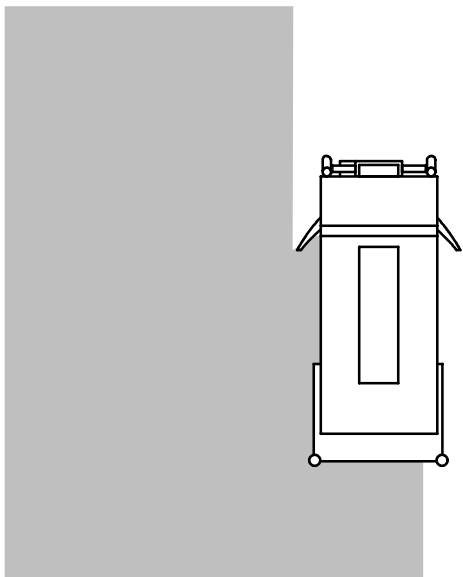

OVERLAPPING SCRUBBING PATHS

04362

Adjust the machine speed, scrub brush pressure, and solution flow as required. Use minimum scrub brush pressure and solution flow required for the best scrubbing results.

When the recovery tank is almost full, the recovery tank full indicator will glow. The recovery tank will have to be drained and cleaned as described in *TO DRAIN AND CLEAN RECOVERY TANK*. Then refill the solution tank with clean water and detergent and continue scrubbing.

1. Turn the key-operated on-off switch clockwise to turn the machine on.
2. Release the machine parking brake, if equipped.
3. Drive the machine to the area to be scrubbed.
4. Pre-Sweep™ equipped machines: Lower the Pre-Sweep™ brush.
5. Press the squeegee switch to lower the squeegee and start the vacuum fan.
6. Press the scrub brush switch to start the brushes turning.
7. Move the solution lever up to start solution flow.

ES™ machines: Press the ES™ switch to stop the ES™ pump, if wanted.

8. Scrub as required.

! WARNING: Flammable Materials Or Reactive Metals Can Cause Explosion Or Fire. Do Not Pick Up.

NOTE: The recovery tank full indicator will not glow on ES™ machines when the ES™ switch is in the "on" position unless a large amount of standing water was picked up.

TO DRAIN AND CLEAN RECOVERY TANK

1. Move the solution lever all the way down to stop solution flow.
2. Press the scrub brush switch to stop and raise the brushes.
3. Press the squeegee switch to raise the squeegee and stop the vacuum.
4. Stop the machine next to a floor drain.

OPERATION

- Turn off the machine and set the machine parking brake, if equipped.

FOR SAFETY: Before Leaving Or Servicing Machine; Stop On Level Surface, Set Parking Brake (If Equipped), And Turn Off Machine And Remove Key.

- Remove and unplug the recovery tank drain hose into a floor drain.

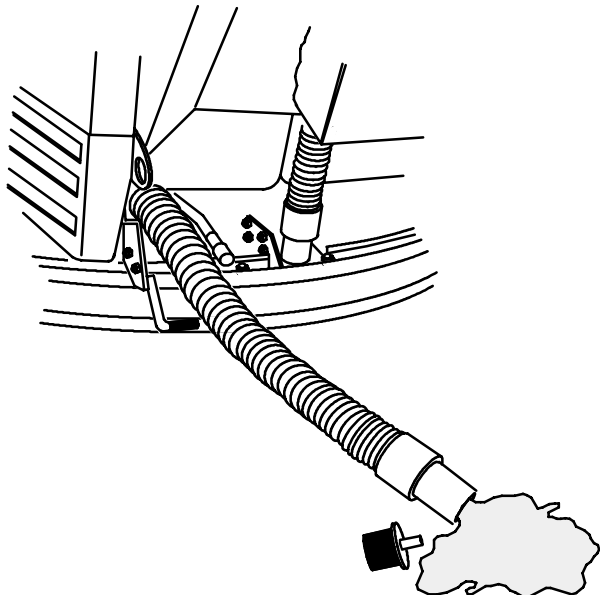

DRAINING RECOVERY TANK

04349

- Open the machine hood.
- Remove the recovery tank cover and duct assembly.
- Spray the inside of the recovery tank with clean water. Remove and clean the fan inlet screen, then place it back into the recovery tank. If the screen is not replaced, damage to the vacuum fan motor could take place. Do not use water hotter than 130° F (54° C) or use steam to clean the tank as it will damage it.

ES™ machines: Flush the ES™ outlet filter and the solution tank outlet filter with water. Then add enough water to cover the recovery tank ES™ outlet filter and operate the ES™ pump to flush the system.

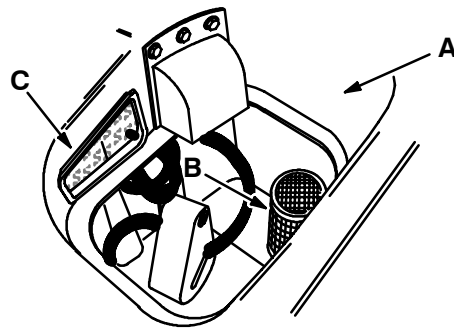

ES™ RECOVERY TANK OUTLET FILTER

04350

- A. Recovery Tank
- B. ES™ Outlet Filter
- C. Fan Inlet Screen

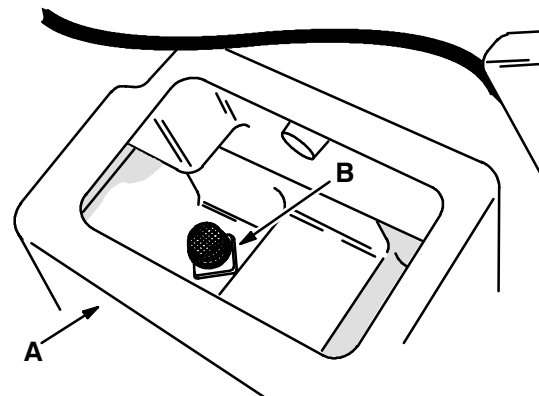

SOLUTION TANK OUTLET FILTER

04355

- A. Solution Tank
- B. Solution Tank Outlet Filter

Pre-Sweep™ equipped machines: Remove and clean out the debris hopper. Replace the hopper into the Pre-Sweep™ assembly.

- Place the duct assembly in the recovery tank opening. Replace the recovery tank lid.

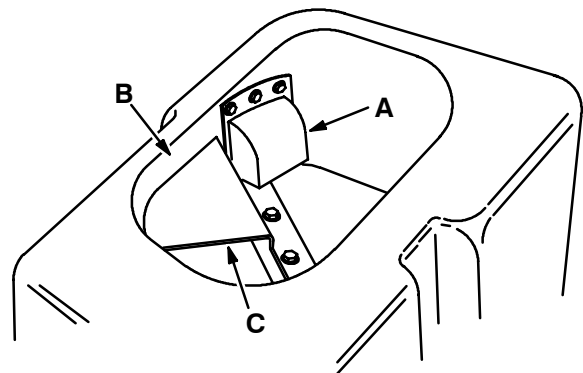

VACUUM FAN DUCT ASSEMBLY

04377

- A. Vacuum Outlet Deflector
- B. Recovery Tank Opening
- C. Duct Assembly

- Remove the squeegee suction hose

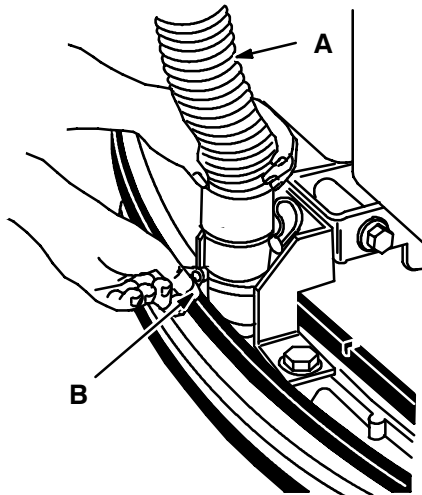

04373

REMOVING SQUEEGEE SUCTION HOSE

- A. Squeegee Hose**
- B. Clamp**

- Push a garden hose into the end of the squeegee suction hose. Turn on the vacuum. Turn on the garden hose.
- Work the garden hose up the squeegee suction hose to flush away any debris.
- Turn off the garden hose and vacuum. Remove the garden hose from the suction hose and push the suction hose back onto the squeegee frame. Tighten the hose clamp around the suction hose.
- Close the machine hood.

- Plug and secure the drain hose in its storage clip.

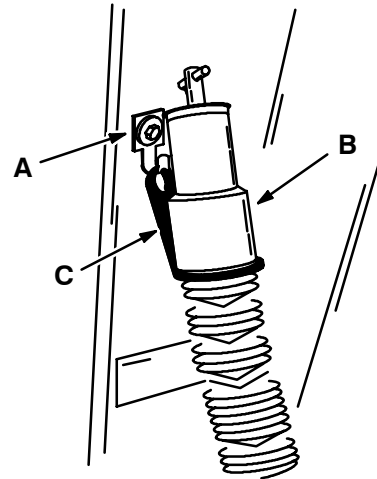

04358

SECURED DRAIN HOSE

- A. Storage Clip**
- B. Drain Hose**
- C. Hose Strap**

POST OPERATION CHECKLIST - MACHINE ON

Check the squeegees for proper deflection.

TO STOP MACHINE

- Move the solution lever all the way down to stop solution flow.
- Press the scrub brush switch to stop and raise the brushes.
- Press the vacuum switch to stop the vacuum and raise the squeegee.
- Turn off the machine and set the machine parking brake, if equipped.

FOR SAFETY: Before Leaving Or Servicing Machine; Stop On Level Surface, Set Parking Brake (If Equipped), And Turn Off Machine And Remove Key.

OPERATION

POST OPERATION CHECKLIST - MACHINE OFF

Check for wire or string tangled on the scrub brushes.

Check the squeegees for wear or damage.

Drain and clean the recovery tank.

ES™ machines: Drain and clean the solution tank. Back flush the pump and hoses.

Check the vacuum hoses for debris or obstructions.

Check for leaks.

DOUBLE SCRUBBING OPERATION

Double scrubbing is a method of removing heavy accumulations of soilage, dirt, wax, or spills. It involves making two passes over the area to be cleaned.

To double scrub, make a single pass over the surface being cleaned with the squeegee up and the vacuum system off. This dispenses solution and allows the brushes to scrub the debris loose. Allow the solution to soak on the floor for 15 to 20 minutes. Then make a second scrubbing pass in the normal manner with the squeegee down.

OPERATION ON GRADES

Drive the machine slowly on grades.

FOR SAFETY: When Using Machine, Go Slow On Grades And Slippery Surfaces.

The maximum rated climb and descent angle is 6° for all machines.

When descending ramps, control machine speed by using the steering handles to reduce the forward speed. The motor controls provide a natural braking action.

When climbing ramps, if the drive motor circuit breaker trips, walk the machine down the ramp to a level surface where the circuit breaker may be reset.

MACHINE TROUBLESHOOTING

| Problem | Cause | Remedy |
|--|--|---|
| Trailing water – poor or no water pickup | Worn rear squeegee | Rotate or replace rear squeegee blade |
| | Rear squeegee out of adjustment | Adjust rear squeegee |
| | Vacuum hose clogged | Flush vacuum hoses |
| | Recovery tank full | Drain tank |
| | Float stuck shutting off vacuum | Clean float |
| | Debris caught on squeegee | Remove debris |
| | Foam filling recovery tank | Empty recovery tank; use less or change detergent |
| | Vacuum hose to rear squeegee disconnected or damaged | Reconnect or replace vacuum hose |
| | Recovery tank lid not seated on the recovery tank | Reinstall recovery tank lid |
| Little or no solution flow to floor | Solution tank empty | Fill solution tank |
| | Solution control cable broken or out of adjustment | Replace and/or adjust cable |
| | Solution supply lines plugged | Flush solution supply lines |
| Poor scrubbing performance | Debris caught on scrub brushes | Remove debris |
| | Improper detergent or brushes used | Check with TENNANT representative for advice |
| | Worn scrub brushes | Replace scrub brushes |
| ES™ system does not fill solution tank | Clogged solution pump or lines | Flush ES™ system |

OPTIONS OPERATION

VACUUM WAND ATTACHMENT

The vacuum wand accessory gives the machine the added flexibility of picking up spills not accessible by the machine. A 90 in (2280 mm) long hose utilizes the machine vacuum system.

TO OPERATE VACUUM WAND ATTACHMENT

1. Turn the machine off and set the machine parking brake, if equipped.

FOR SAFETY: Before Leaving Or Servicing Machine; Stop On Level Surface, Set Parking Brake (If Equipped), And Turn Off Machine And Remove Key.

2. Remove the vacuum wand equipment from the vacuum wand bag.

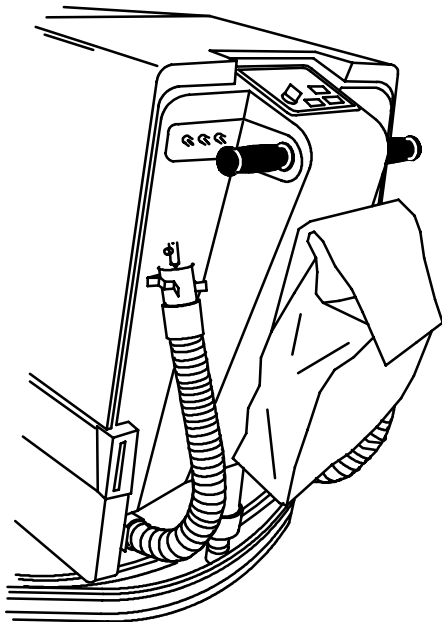

VACUUM WAND BAG

04387

3. Disconnect the squeegee suction hose from the squeegee assembly.

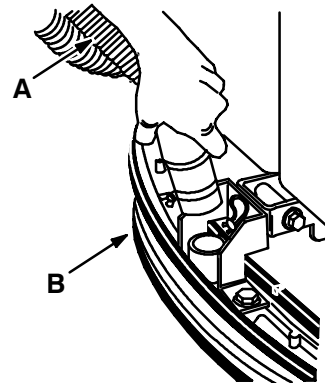

DISCONNECTING SQUEEGEE SUCTION HOSE

04363

- A. Suction Hose**
- B. Squeegee**

4. Push the vacuum wand hose connector into the squeegee suction hose.
5. Assemble the wand and hose.
6. Make sure the scrub brushes are raised.
7. Press the squeegee switch to start the vacuum fan.
8. Vacuum as required.
9. When finished, press the squeegee switch to stop the vacuum fan.
10. Remove the vacuum wand hose from the squeegee suction hose.
11. Reconnect the squeegee suction hose to the squeegee assembly.
12. Clean and rinse off the vacuum wand and equipment.
13. Store the vacuum wand equipment in the vacuum wand bag.

POWER WAND

The power wand uses the vacuum system and solution system of the machine. The wand allows scrubbing of floors which are out of reach by the machine.

TO OPERATE THE POWER WAND

1. Turn off the machine and set the machine parking brake.

FOR SAFETY: Before Leaving Or Servicing Machine; Stop On Level Surface, Set Parking Brake(If Equipped), Turn Off Machine And Remove Key.

2. Remove the power wand equipment from the machine hood.
3. Pull the squeegee vacuum hose off the rear squeegee assembly.

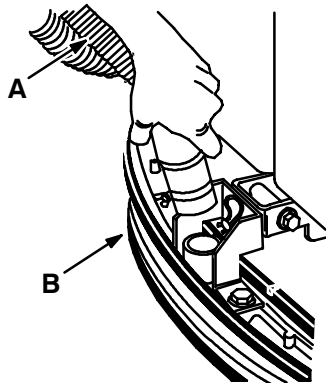

04363

DISCONNECTING SQUEEGEE SUCTION HOSE

- A. Squeegee Suction Hose**
- B. Rear Squeegee Assembly**

4. Attach the adapter to the end of the power wand vacuum hose if not already connected.
5. Push the power wand vacuum hose onto the squeegee vacuum hose.
6. Attach the solution hose to the quick-disconnect on the machine.

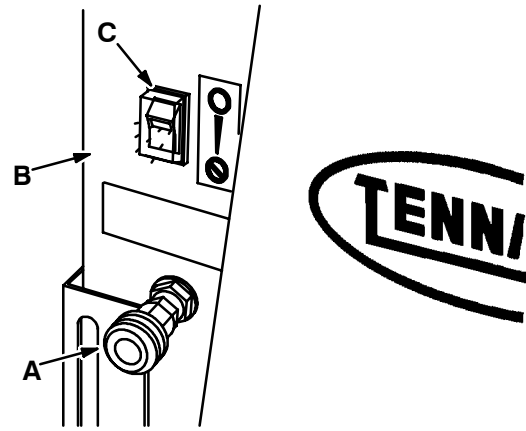

08078

SOLUTION QUICK-DISCONNECT

- A. Quick-disconnect**
- B. Rear Panel**
- C. Power Wand Switch**

7. Attach the other ends of the solution and vacuum hoses to the power wand tool in the same way.

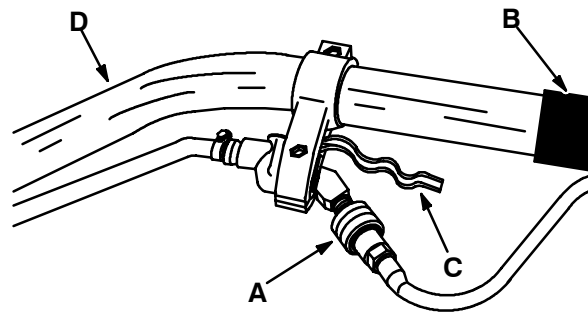

06598

CONNECTING ATTACHMENT

- A. Solution Hose Quick-Disconnect**
- B. Vacuum Hose**
- C. Valve Handle**
- D. Selected Attachment**

8. Make sure the scrub brushes are raised.
9. Press the squeegee switch to start the vacuum fan.
10. Start the solution flow to the power wand by placing the power wand switch in the **ON** position.
11. Squeeze the solution lever on the power wand to spray solution on the floor. Scrub the floor with the brush side of the cleaning tool.

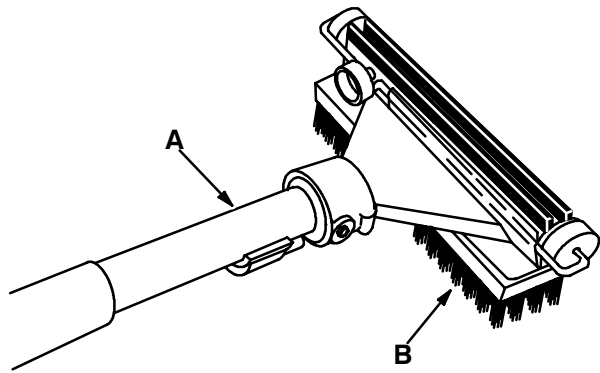

POWER WAND

06601

- A. Cleaning Tool
- B. Brush

12. Vacuum the solution by turning the cleaning tool so the squeegee side is down.

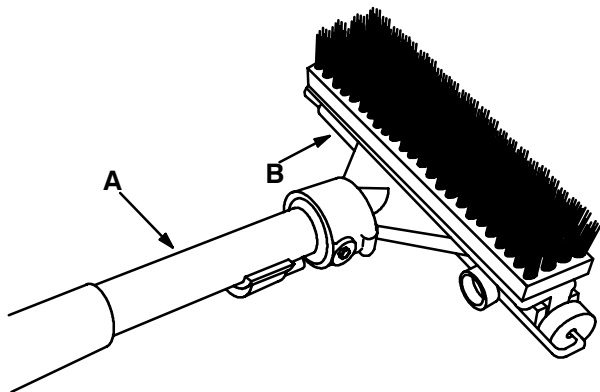

POWER WAND

06602

- A. Cleaning Tool
- B. Squeegee

If the Power wand is difficult to push or does not pickup the solution very well, adjust the roller wheels on the tool by turning the black adjustment knob.

NOTE: The wheels are properly adjusted when the squeegee blades deflect slightly while the tool is pushed back and forth.

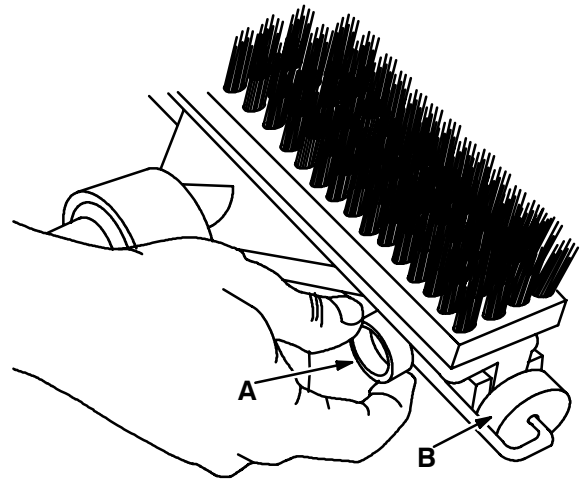

ADJUSTING ROLLER WHEELS

06604

- A. Adjustment Knob
- B. Roller Wheels

13. When finished, stop the solution flow to the power wand by putting the power wand switch in the **OFF** position.
14. Press the vacuum fan switch again to turn off the vacuum.
15. Disconnect the solution hose from the machine quick-disconnect.
16. Remove the power wand vacuum hose from the squeegee suction hose.
17. Reconnect the squeegee suction hose to the rear squeegee assembly.
18. Disconnect the vacuum and solution hoses from the power wand.
19. Replace the power wand equipment in its storage location on top of the machine hood.

PRE-SWEEP™

The Pre-Sweep™ assembly gives the machine added ability to pick up debris. The assembly is mounted to the front of the machine. It contains a brush which sweeps debris into a debris hopper. Periodically empty the hopper as it fills with debris.

The machine may be operated with or without the Pre-Sweep™ assembly. Refer to *PRE-SWEEP™* in the *MAINTENANCE* section for maintenance and adjustments.

TO REMOVE PRE-SWEEP™

1. Turn the machine off and set the machine parking brake, if equipped.

FOR SAFETY: Before Leaving Or Servicing Machine; Stop On Level Surface, Set Parking Brake (If Equipped), And Turn Off Machine And Remove Key.

2. Unplug the Pre-Sweep™ assembly wire harness from the machine wire harness.

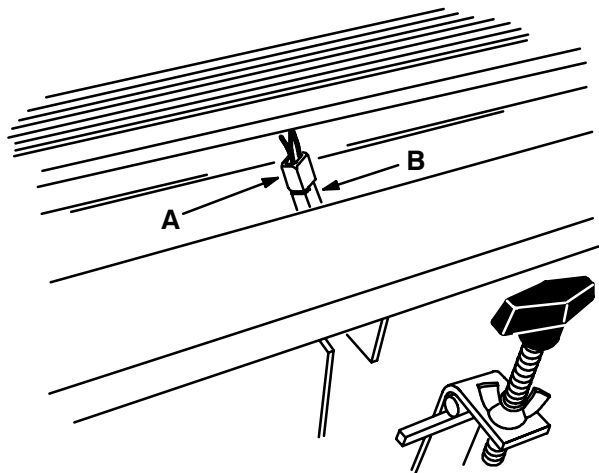

PRE-SWEEP™ WIRE HARNESS

04386

- A. Machine Wire Harness
- B. Pre-Sweep™ Wire Harness

3. Raise the Pre-Sweep™ brush.
4. Remove the two quick release pins from the machine mounting brackets and the Pre-Sweep™ assembly. Place the pins in the Pre-Sweep™ assembly.

5. Remove the cotter pin holding the third caster in its storage location.

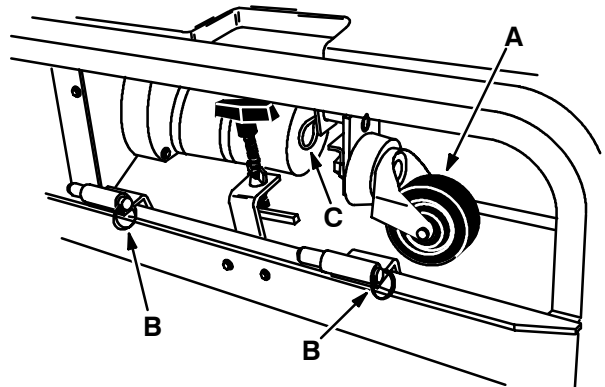

04384

PRE-SWEEP™ ASSEMBLY

- A. Third Caster
- B. Quick Release Pins
- C. Cotter Pin

6. Mount the third caster to the Pre-Sweep™ frame.

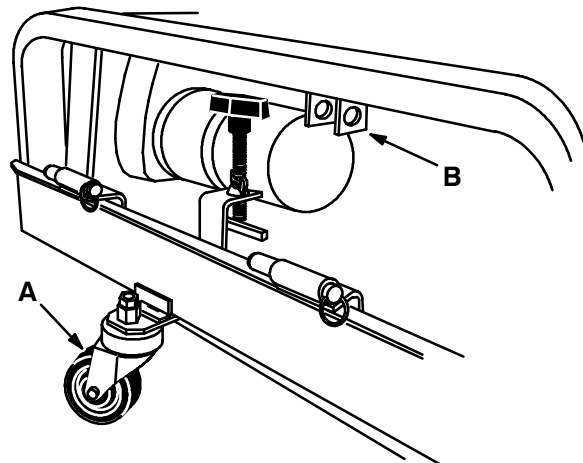

04383

PRE-SWEEP™ THIRD CASTER

- A. Third Caster
- B. Storage Location

OPERATION

TO MOUNT THE PRE-SWEEP™

1. Turn the machine off and set the machine parking brake, if equipped.

FOR SAFETY: Before Leaving Or Servicing Machine; Stop On Level Surface, Set Parking Brake (If Equipped), And Turn Off Machine And Remove Key.

2. Pull out the cotter pin holding the third caster to the frame.

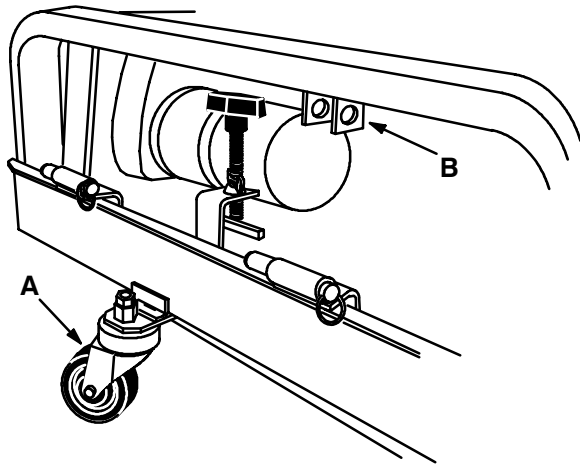

PRE-SWEEP™ THIRD CASTER

04383

- A. Third Caster
- B. Storage Location

3. Place the third caster in the storage location and secure with the cotter pin.

4. Remove the two quick release pins from the Pre-Sweep™ frame.

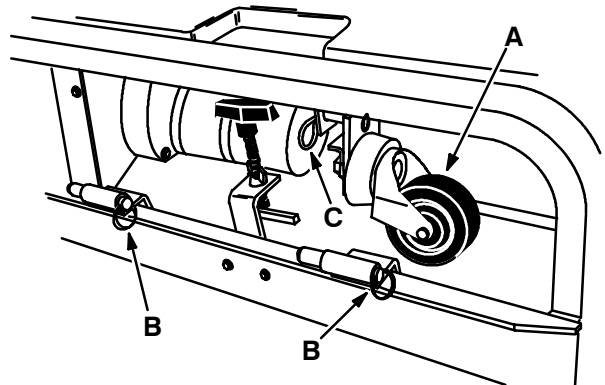

04384

PRE-SWEEP™ ASSEMBLY

- A. Third Caster
- B. Quick Release Pins
- C. Cotter Pin

5. Line up the quick release on the Pre-Sweep™ with the mounting brackets on the front of the machine.

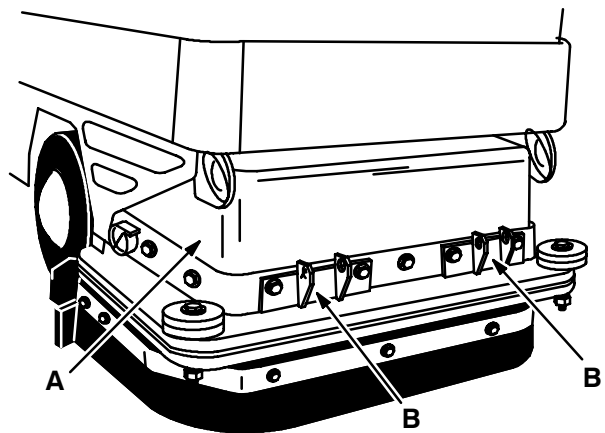

04366

PRE-SWEEP™ MOUNTING BRACKETS

- A. Front of Machine
- B. Mounting Bracket

6. Push the quick release pins through the mounting bracket holes and the quick release pin holes.
7. Remove the debris hopper from the Pre-Sweep™ assembly.
8. Plug the wire harness from the machine into the Pre-Sweep™ assembly wire harness.

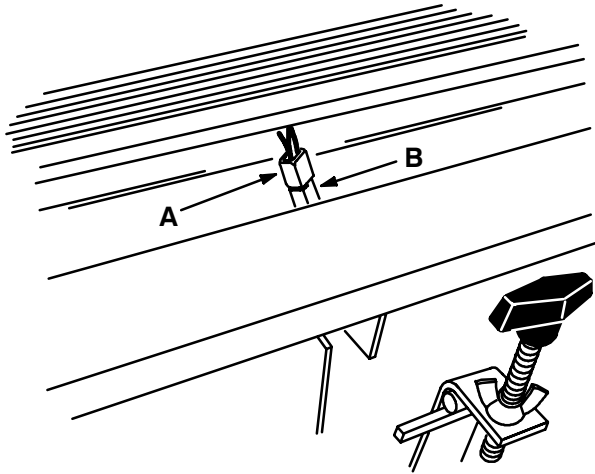

04386

PRE-SWEEP™ WIRE HARNESS

- A. Machine Wire Harness**
- B. Pre-Sweep™ Wire Harness**

9. Replace the debris hopper.

TRANSPORTING MACHINE

PUSHING OR TOWING MACHINE

The machine may be pushed or towed up to 4 mph (6 km/h) by the machine frame. Use care when attaching towing cables or chains to avoid damaging the machine.

MACHINE JACKING

The machine may be jacked up for service at the designated locations. Use a jack of adequate capacity and good working condition. Always stop the machine on a flat, level surface and block the tires before jacking the machine up.

The front jacking location is the flat bottom edge of the front of the machine frame. The rear jacking locations are on the flat bottom edge of the rear of the machine frame.

TO JACK UP MACHINE

1. Empty the solution and recovery tanks.
2. Turn the machine off and set the machine parking brake, if equipped.

FOR SAFETY: Before Leaving Or Servicing Machine; Stop On Level Surface, Set Parking Brake (If Equipped), And Turn Off Machine And Remove Key.

3. Block the tires, which are not being jacked up, in order to secure the machine position.

FOR SAFETY: When Servicing Machine, Block Machine Tires Before Jacking Machine Up.

4. Use a jack of adequate capacity to raise the machine. Jack up the machine only at the designated locations.

FOR SAFETY: When Servicing Machine: Jack Machine Up At Designated Locations Only. Block Machine Up With Jack Stands. Use Hoist Or Jack Of Adequate Capacity To Lift Machine.

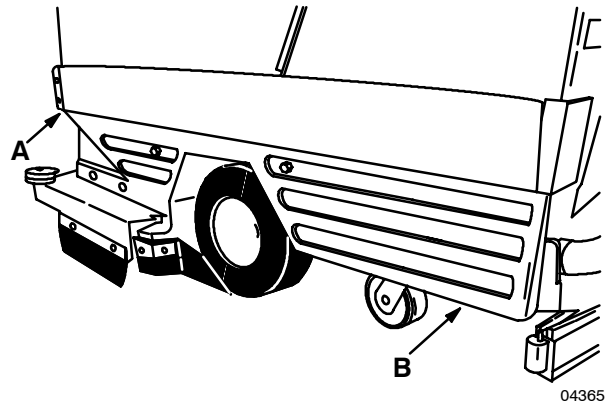

JACKING LOCATIONS

- A. Front Jacking Location
- B. Rear Jacking Location

5. Block machine up with jack stands or similar devices next to the designated jacking locations to secure the machine.
6. Lower the machine onto the jack stands.
7. Check to make sure the machine is secure.
8. Service the machine as required.
9. When finished servicing the machine, raise the machine off the jack stands.
10. Remove the jack stands from under the machine.
11. Lower the machine.
12. Remove the blocks from the tires.

MACHINE TIE-DOWNS

The machine may be tied down at each corner of the main frame using the tie-down brackets supplied in the tie-down kit.

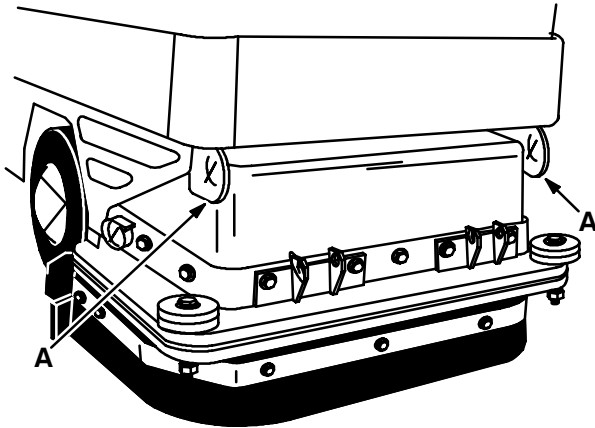

04366

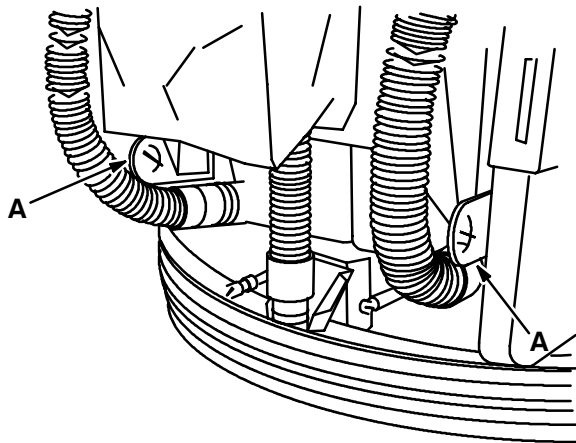
FRONT TIE-DOWN LOCATIONS**A. Tie-Down Bracket**

04382

REAR TIE-DOWN LOCATION**A. Tie-Down Bracket**

When transporting the machine on a trailer or in a truck, be sure to engage the machine parking brake if present and block the machine tires to prevent the machine from rolling.

MACHINE STORAGE

STORING MACHINE

When storing the machine for extended periods of time, the following procedures must be followed to lessen the chance of rust, sludge, or other undesirable deposits from forming.

1. Drain and clean the solution and recovery tanks.
2. Remove and empty Pre-Sweep™ assembly.
3. Raise the scrub brushes.
4. Park the machine in a cool, dry area.
5. Remove the batteries or charge the batteries after every three months.

SECTION 3

CONTENTS

| | Page | | Page |
|-----------------------------------|------|---------------------------------|------|
| RECOMMENDED FIRST 50-HOUR MACHINE | | BRAKES AND TIRES | 3-22 |
| INSPECTION | 3-3 | PARKING BRAKE | 3-22 |
| MAINTENANCE CHART | 3-4 | TIRES | 3-22 |
| LUBRICATION | 3-5 | OPTIONS | 3-23 |
| REAR CASTERS | 3-5 | PRE-SWEEP™ | 3-23 |
| WHEEL DRIVE CHAIN | 3-5 | PRE-SWEEP™ BRUSH | 3-23 |
| ELECTRICAL SYSTEM | 3-6 | TO REPLACE PRE-SWEEP™ | |
| BATTERIES | 3-6 | BRUSH | 3-23 |
| TO CHARGE BATTERIES | 3-7 | TO ADJUST PRE-SWEEP™ BRUSH | |
| ELECTRIC MOTORS | 3-8 | PATTERN | 3-24 |
| ELECTRICAL SCHEMATIC | 3-9 | PRE-SWEEP™ BRUSH SIDE SKIRTS | 3-24 |
| BELTS AND CHAINS | 3-10 | PRE-SWEEP™ BRUSH DRIVE BELT | 3-24 |
| WHEEL DRIVE CHAIN | 3-10 | TO REPLACE AND ADJUST THE BRUSH | |
| STATIC DRAG CHAIN | 3-10 | DRIVE BELT | 3-24 |
| SCRUB HEAD | 3-11 | PRE-SWEEP™ REAR SKIRT | 3-25 |
| SCRUB HEAD | 3-11 | DEBRIS HOPPER SLIT SKIRT | 3-26 |
| TO LEVEL SCRUB HEAD | 3-11 | PRE-SWEEP™ HOPPER SEALS | 3-26 |
| SCRUB BRUSHES | 3-12 | | |
| TO REPLACE SCRUB BRUSHES | 3-12 | | |
| SCRUB HEAD FLOOR SKIRT | 3-13 | | |
| SOLUTION AND RECOVERY TANKS | 3-14 | | |
| SOLUTION TANK | 3-14 | | |
| SOLUTION VALVE | 3-14 | | |
| RECOVERY TANK | 3-15 | | |
| TO DRAIN AND CLEAN RECOVERY | | | |
| TANK | 3-15 | | |
| SQUEEGEES | 3-17 | | |
| REAR SQUEEGEE | 3-17 | | |
| TO REMOVE SQUEEGEE | | | |
| ASSEMBLY | 3-17 | | |
| TO INSTALL SQUEEGEE ASSEMBLY | 3-18 | | |
| TO REPLACE OR ROTATE BLADE | 3-18 | | |
| TO LEVEL REAR SQUEEGEE (for 1465 | | | |
| with serial number below 030065, | | | |
| or 1480 with serial number | | | |
| below 040161) | 3-19 | | |
| TO LEVEL REAR SQUEEGEE (for | | | |
| 1465 number 030065 and above, | | | |
| 1480 serial number 040161 | | | |
| and above, and 1490 machines) | 3-19 | | |
| TO ADJUST SQUEEGEE DEFLECTION | | | |
| (for 1465 with serial number | | | |
| below 030065, or 1480 with | | | |
| serial number below 040161) | 3-20 | | |
| TO ADJUST SQUEEGEE DEFLECTION | | | |
| (for 1465 number 030065 and | | | |
| above, 1480 serial number | | | |
| 040161 and above, and 1490 | | | |
| machines) | 3-21 | | |

RECOMMENDED FIRST 50-HOUR MACHINE INSPECTION

After the first 50 hours of operation, the following procedures are recommended:

1. Check the squeegee deflection.
2. Check the specific gravity of the batteries.
3. Check the battery cable connections.
4. Check the scrub head side skirts adjustment.
5. Check the tire pressure in the drive wheel tires.

MAINTENANCE CHART

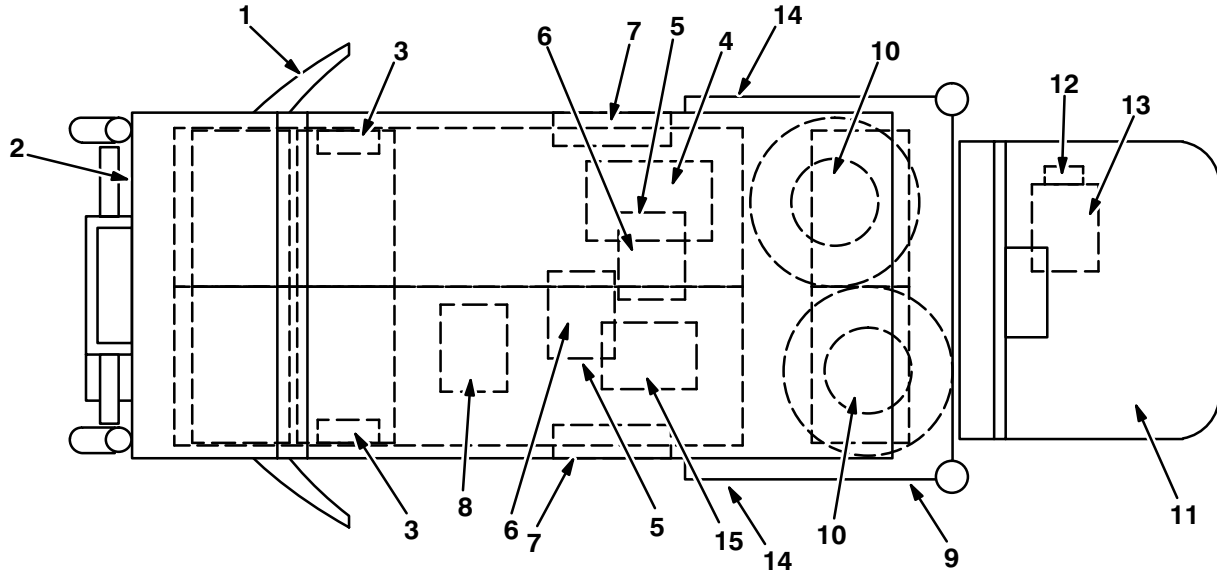

04354

| Interval | Key | Description | Procedure | Lubricant/ Fluid | No. of Service Points |
|-----------|-----|-----------------------------|--|---------------------|-----------------------------|
| Daily | 1 | Squeegee | Check for damage and wear | – | 1 |
| | 10 | Scrub brushes | Check for damage and wear | – | 2 |
| | 4 | Recovery tank | Clean Back flush squeegee suction hose | – | 1 |
| | 15 | ES™ solution tank | Clean and flush | – | 1 |
| | 11 | Pre-Sweep™ brush | Check for damage and wear | – | 1 |
| 25 Hours | 9 | Scrub head floor skirts | Check for damage and wear | – | 3 |
| | 1 | Squeegee | Check deflection | – | 1 |
| | 7 | Front tires | Check air pressure | – | 2 |
| | 11 | Pre-Sweep™ | Check skirts and seals for damage and wear | – | 6 |
| 80 Hours | 14 | Scrub head side skirts | Check for adjustment | – | 2 |
| | 12 | Pre-Sweep™ brush drive belt | Check tension | – | 1 |
| | 11 | Pre-Sweep™ side skirts | Check floor clearance | – | 2 |
| 100 Hours | 3 | Rear casters | Lubricate | SPL | 2 |
| | 2 | Parking brake | Check adjustment | – | 1 |
| | 5 | Wheel drive chains | Lubricate | SPL | 2 |
| 160 Hours | 8 | Vacuum fan motor | Check motor brushes | – | 1 |
| | 10 | Scrub brush motors | Check motor brushes | – | 2 |
| | 6 | Propelling motors | Check motor brushes | – | 2 |
| | 13 | Pre-Sweep™ brush motor | Check motor brushes | – | 1 |

SPL – Special lubricant, Lubriplate EMB grease (TENNANT part no. 01433–1)

NOTE: More frequent intervals may be required in extremely dusty applications.

LUBRICATION

REAR CASTERS

The two rear casters support the weight of the rear of the machine. Grease fittings have been provided for lubrication purposes. They are located on the swivel and on the wheel. Lubricate the swivel and wheel with a grease gun containing Lubriplate EMB grease (TENNANT part no. 01433-1) after every 100 hours of operation.

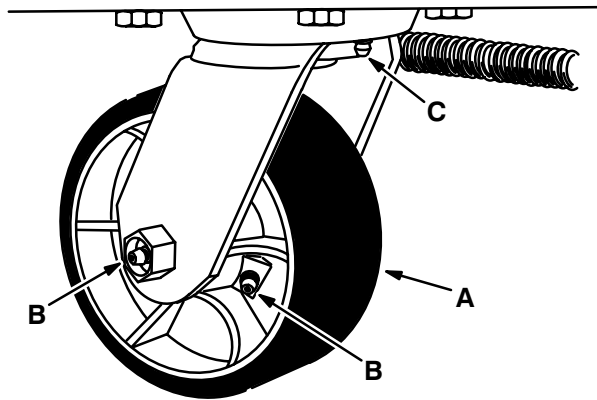

REAR CASTER

- A. Caster
- B. Wheel Grease Fitting
- C. Swivel Grease Fitting

04352

WHEEL DRIVE CHAIN

The wheel drive chain transfers power from the propelling motor to the front wheels. Lubricate the chain by brushing some Lubriplate EMB grease (TENNANT part no. 01433-1) on the chains after every 100 hours of operation.

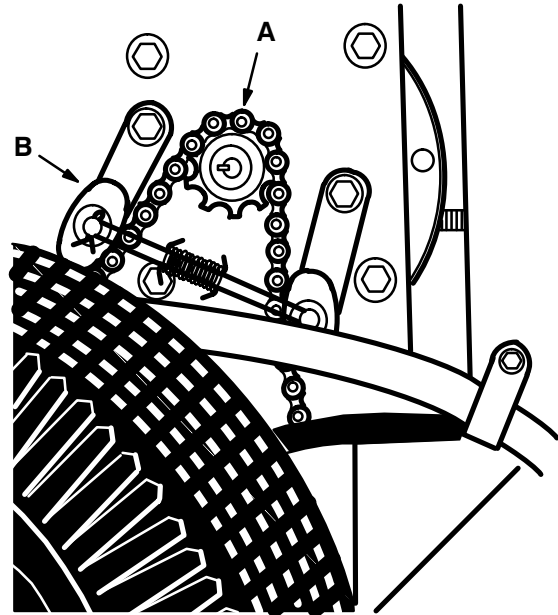

WHEEL DRIVE CHAIN

- A. Chain
- B. Chain Tensioner

04353

ELECTRICAL SYSTEM

BATTERIES

The six 6-Volt batteries provide all of the energy used by the machine. The batteries are rated at 220 A/h at a 20-hour rate. The heavy duty batteries are available as an option on the 1480, and 1490. They are rated at 305 A/h at a 20 hour rate. The batteries require regular maintenance to keep them operating their best.

Periodically clean the top surface and the terminals and check for loose connections. Use a strong solution of baking soda and water. Brush the solution sparingly over the battery top, terminals, and cable clamps. Do not allow any baking soda solution to enter the battery. Use a wire brush to clean the terminal posts and the cable connectors. After cleaning, apply a coating of clear petroleum jelly to the terminals and the cable connectors. Keep the tops of the batteries clean and dry.

Check the electrolyte level in each battery cell before and after charging the batteries. Never add acid to batteries, only distilled water. Do not overfill. Keep vent plugs firmly in place at all times, except when adding water or taking hydrometer readings.

FOR SAFETY: When Servicing Machine, Avoid Contact With Battery Acid.

Do not operate machine if batteries are in poor condition or have a charge level below 25%, specific gravity below 1.155. Do not allow batteries to remain in discharged condition for any length of time.

Keep all metallic objects off the top of the batteries, as they may cause a short circuit. Replace worn or damaged wires.

The machine batteries are unique in that they hold their power for long periods of time, but they can only be recharged a certain number of times. To get the most life from the batteries, charge them when their charge level is below 25%. To determine the charge level, check the batteries specific gravity with a hydrometer.

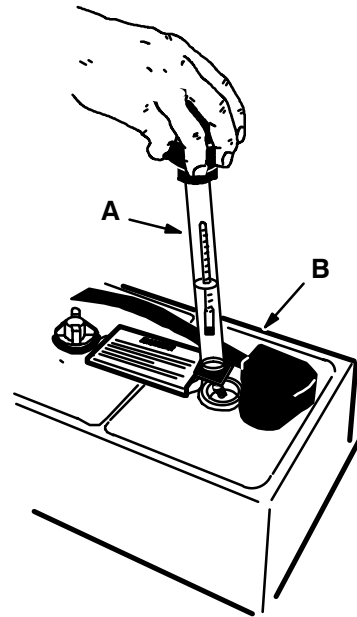

04380

CHECKING BATTERY SPECIFIC GRAVITY

- A. Hydrometer**
- B. Battery**

If one or more battery cells tests lower than the other battery cells, (0.050 or more) the cell is damaged, shorted, or is about to fail.

NOTE: Do not take readings immediately after adding water—if the water and acid are not thoroughly mixed, the readings may not be accurate. Check the hydrometer readings against the following chart:

| Specific Gravity at 80° F (27° C) | Battery Condition |
|--|--------------------------|
| 1.265 | 100% charged |
| 1.225 | 75% charged |
| 1.190 | 50% charged |
| 1.155 | 25% charged |
| 1.120 | Discharged |

NOTE: If the readings are taken when the battery electrolyte is any temperature other than 80° F (27° C), the reading must be temperature corrected.

To determine the corrected specific gravity reading when the temperature of the battery electrolyte is other than 80° F (27° C):

Add to the specific gravity reading 0.004, 4 points, for each 10° F (6° C) above 80° F (27° C).

Subtract from the specific gravity reading 0.004, 4 points, for each 10° F (6° C) below 80° F (27° C).

Eight to twelve hours is generally enough time to charge a discharged set of batteries. If the batteries are not fully discharged, charge for a period of time that is proportionally less than what is required for a fully discharged set of batteries, ie: half discharged batteries need four to six hours of charging time.

Do not expose the battery charger to water. Do not touch uninsulated battery terminals or unnecessarily expose any portion of your body to the batteries when making electrical connections.

TO CHARGE BATTERIES

1. Stop the machine on a flat, dry surface next to the charger and engage the machine parking brake, if equipped.

FOR SAFETY: Before Leaving Or Servicing Machine; Stop On Level Surface, Set Parking Brake (If Equipped), And Turn Off Machine And Remove Key.

2. Turn the key-operated on-off switch counter-clockwise to stop the machine.
3. Lift open the machine hood, and tilt open the rear cover.



WARNING: Batteries Emit Hydrogen Gas. Explosion Or Fire Can Result. Keep Sparks And Open Flame Away. Keep Covers Open When Charging.

4. Check the electrolyte level in the batteries.

Before charging, add just enough distilled water to cover the plates. Then, after charging is completed, add enough water to bring the level up to the indicator ring. If the water level is topped off before charging, normal expansion of the electrolyte may cause an overflow, resulting in loss of acid balance and damage to the machine.

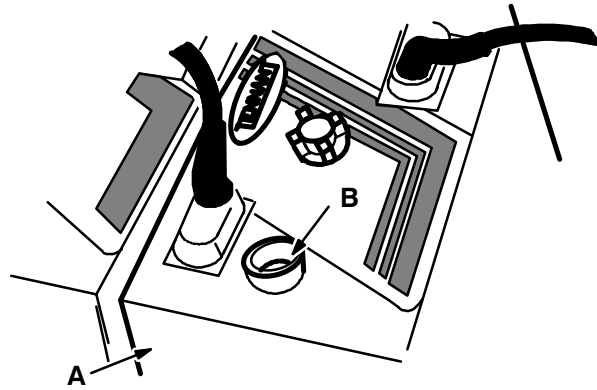

00879

ELECTROLYTE INDICATOR RING

- A. Battery
- B. Indicator Ring

5. Replace battery caps and leave them in place while charging.
6. Unplug the machine connector from the battery connector.

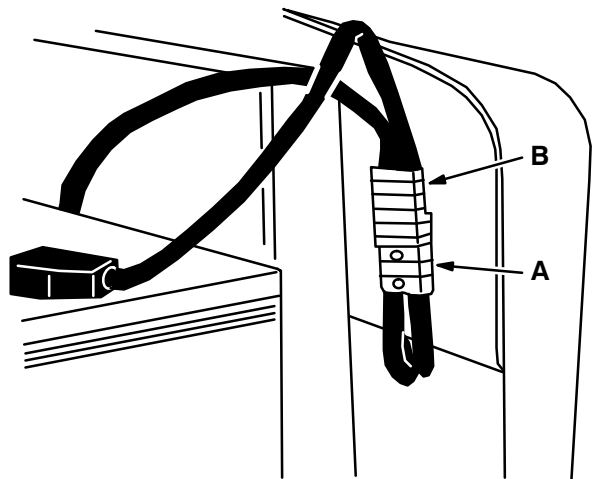

04343

CONNECTING BATTERY CONNECTORS

- A. Machine Connector
- B. Battery Connector

- Non-Smart Chargers: Plug the charger connector into the battery connector. The charger will start automatically in three to five seconds. The charger will turn off when the batteries are fully charged.

Smart Chargers: Plug the charger connector into the battery connector. The charger will go through a self diagnostic check. All the indicator lamps on the charger panel will flash showing the diagnostic check is in progress.

NOTE: If the red no charge indicator lamp lights when the charger is plugged into a wall outlet, the charger can not charge the battery, meaning there is something wrong with the battery.

When the lamps stop flashing, the *red incomplete battery status indicator lamp* lights. After a short delay, the *yellow charger on indicator lamp* lights showing the charger has turned on.

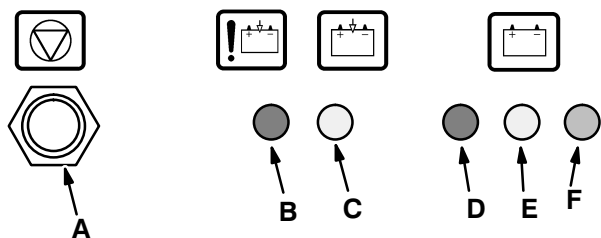

CHARGER PANEL

- A. Interrupt Switch
- B. Red No Charge Indicator Lamp
- C. Yellow Charger On Indicator Lamp
- D. Red Incomplete Battery Status Indicator Lamp
- E. Yellow 80% Charge Indicator Lamp
- F. Green Complete Charge Indicator Lamp

As the battery charges, the *red incomplete battery status indicator lamp* goes out and the *yellow 80% charge indicator lamp* lights.

Finally the *yellow 80% charge indicator lamp* goes out and the *green complete charge indicator lamp* lights showing the battery is completely charged. After a short time, the *yellow charger on indicator lamp* goes out showing the charger has turned off.

The *green complete charge indicator lamp* will remain on until the charger is unplugged from the wall outlet.

*NOTE: If the charge cycle has to be stopped, press the interrupt switch **while** unplugging the charger from the wall outlet.*

- After the charger is off, or after turning the charger off, unplug the charger connector from the battery connector.

NOTE: Make sure the battery charger is off before unplugging the charger connector from the battery connector

- Reconnect the machine connector to the battery connector.
- Check the electrolyte level of the batteries; it should be up to the indicator ring.
- Tilt the rear cover back and close the machine hood.

ELECTRIC MOTORS

The electric motors are repairable. There are six electric motors on the machine – two propelling motors, two scrub brush motors, one vacuum fan motor, and one Pre-Sweep™ brush motor.

Blow out the dust and inspect the motor brushes in the motors after every 160 hours of operation.

If the brushes have been worn to less than 0.38 in (10 mm) in length, replace them.

If the commutator is worn or rough, the motor armature should be removed and serviced.

PROPELLING CIRCUIT

The propelling circuit controls the forward and reverse speed of the machine. The circuit is not user serviceable – only trained personnel should be allowed to work on it. Do not steam clean or spray the panel with water as it may damage the electrical system.

WARNING: Hazardous Voltage. Shock Can Result. Disconnect Batteries Before Working On Machine. Only Qualified Personnel Should Work Inside Panel.

NOTE: A static discharge grounding strap should be used when servicing the electronic circuitry.

BELTS AND CHAINS

WHEEL DRIVE CHAIN

The wheel drive chain transfers power from the propelling motor to the differential on standard machines. It has an automatic tensioner and requires no regular adjustment.

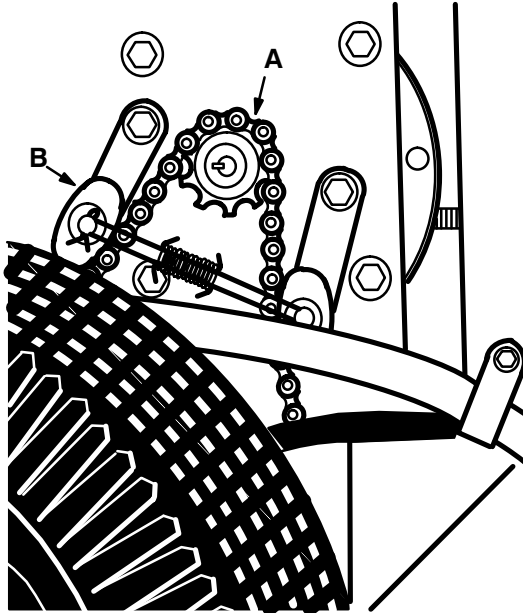

WHEEL DRIVE CHAIN

04353

- A. Chain
- B. Chain Tensioner

STATIC DRAG CHAIN

The static drag chain prevents the buildup of static electricity in the machine. It is attached to the main frame.

Make sure that the chain is making contact with the floor at all times.

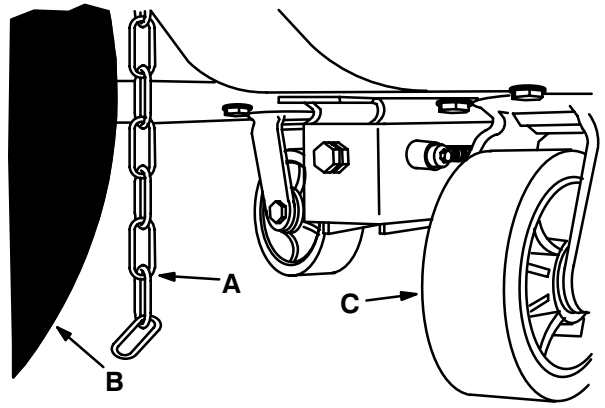

04388

STATIC DRAG CHAIN

- A. Static Drag Chain
- B. Front Tire
- C. Rear Caster

SCRUB HEAD

SCRUB HEAD

The scrub head houses the two scrub brushes, and their drive and lift mechanisms. The scrub head has one adjustment – scrub head leveling. It is factory adjusted and should not be changed unless scrub head parts are damaged or are replaced. If the scrub head is not level, the brushes will apply uneven pressure and may bounce. It also would cause excessive wear on the brush drive plugs and bearings.

TO LEVEL SCRUB HEAD

1. Stop the machine on a smooth, level floor.
2. Lower the scrub brushes.
3. Turn the machine off and set the machine parking brake, if equipped.

FOR SAFETY: Before Leaving Or Servicing Machine; Stop On Level Surface, Set Parking Brake (If Equipped), And Turn Off Machine And Remove Key.

4. Remove the scrub head cover by pressing on the release levers on both sides of the scrub head cover and pulling forward.

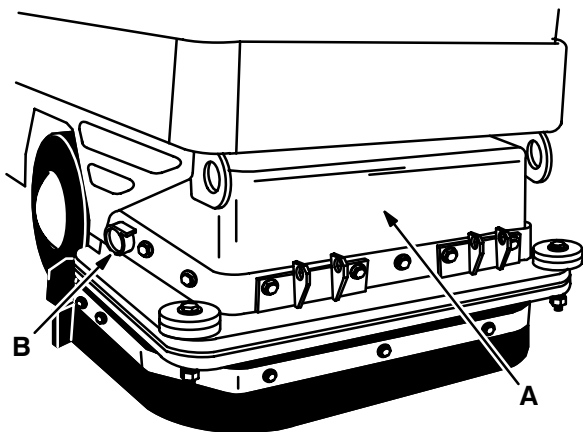

SCRUB HEAD COVER RELEASE

- A. Scrub Head Cover**
- B. Release Lever**

5. Position a level on the scrub head from front to rear.
6. Adjust the support link ball joints so the head is level front to rear. Tighten the ball joint jam nuts after making adjustments.

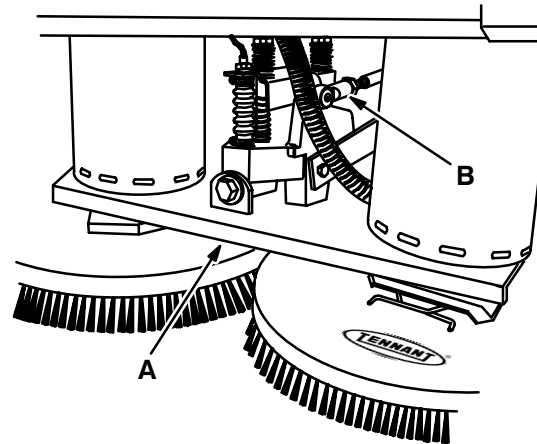

LEVELING SCRUB HEAD

- A. Scrub Head**
- B. Support Link**

7. Start the machine.
8. Raise the scrub brushes.
9. Lower and start the scrub brushes.
10. Turn machine off.
11. Recheck the front to back level of the scrub head. Readjust if necessary.
12. Replace the scrub head cover.

04368

04366

MAINTENANCE

SCRUB BRUSHES

Two disc-type scrub brushes scrub the floor. Each scrub brush is driven by its own electric motor through a floating drive assembly. Part of each floating drive assembly is a spring lock clip which holds the scrub brushes.

There are many variations of brushes and cleaning pads to choose from. There is a brush or cleaning pad available for almost any application. Scrub brushes are ready for use when they are equipped with a brush drive plate and spring clip.

Scrub brushes should be checked daily for tangled wire or string wear damage. Scrub brushes should be replaced if large portions of the brush bristles are missing or if the remaining brush bristle length is less than 0.50 to 0.25 in (15 to 5 mm).

NOTE: Be sure to replace brushes in sets. Otherwise one scrub brush will be more aggressive than the other.

TO REPLACE SCRUB BRUSHES

1. Raise the scrub brushes.
2. Turn machine off and set the parking brake, if equipped.

FOR SAFETY: Before Leaving Or Servicing Machine; Stop On Level Surface, Set Parking Brake (If Equipped), And Turn Off Machine And Remove Key.

3. Remove the scrub head cover by pressing on the release levers on both sides of the scrub head cover and pulling forward.

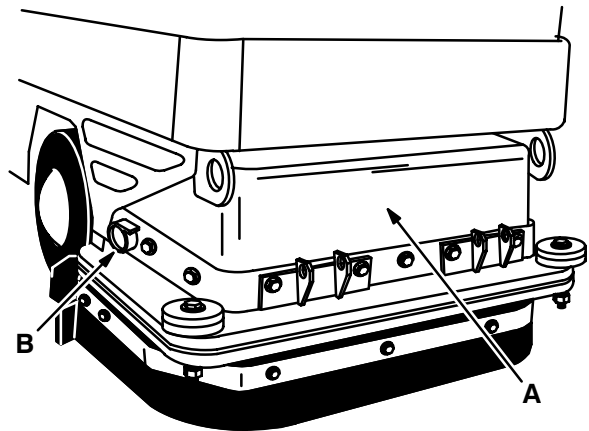

04366

SCRUB HEAD COVER RELEASE

- A. Scrub Head Cover
- B. Release Lever

4. Rotate each of the scrub brushes until you can see their spring clips.

5. Press the spring clips together with your thumb and index finger; press the brush down to remove it.

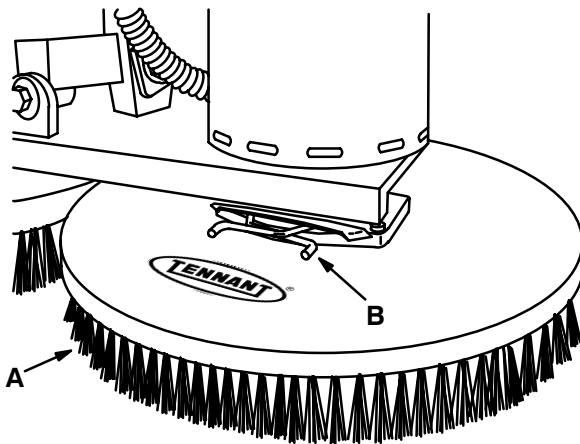

REMOVING SCRUB BRUSH

04367

- A. Scrub Brush
- B. Brush Spring Clip

6. Slide the new scrub brushes under the scrub brush drive assemblies.
7. Line up the scrub brush drive socket with the drive plug.
8. Press the brush spring clip together and lift the scrub brush into the drive plug. Release the spring clip when the brush is in place.
9. Repeat for the other brush.
10. Check the front to back level of the scrub head. Adjust if necessary as described in *TO LEVEL SCRUB HEAD*.
11. Replace the scrub head cover.

SCRUB HEAD FLOOR SKIRT

The scrub head floor skirts control water spray from the brushes. The scrub head side skirts are located just in front of the front wheels. The scrub head cover skirt is located in front of the scrub head. Check these skirts for wear or damage after every 25 hours of operation.

The side skirts should touch the floor when adjusted properly. The scrub head cover skirt should touch the floor when the scrub head is down. Check the floor skirt for adjustment after every 80 hours of operation.

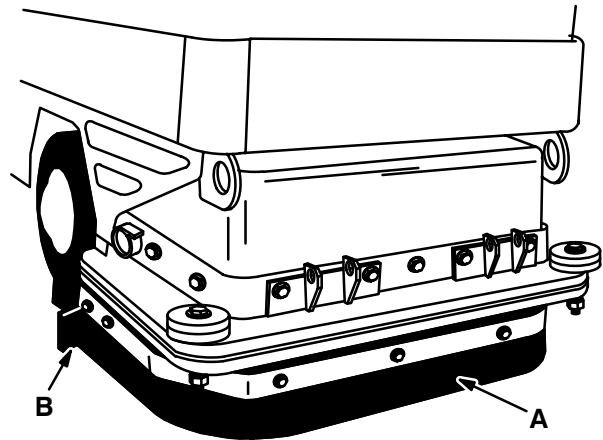

SCRUB HEAD FLOOR SKIRTS

04366

- A. Scrub Head Cover Skirt
- B. Scrub Head Side Skirt

SOLUTION AND RECOVERY TANKS

SOLUTION TANK

The solution tank supplies the scrub brushes with a water and detergent solution. It is the tank located on the right side of the machine.

To get to the solution tank, open the machine hood.

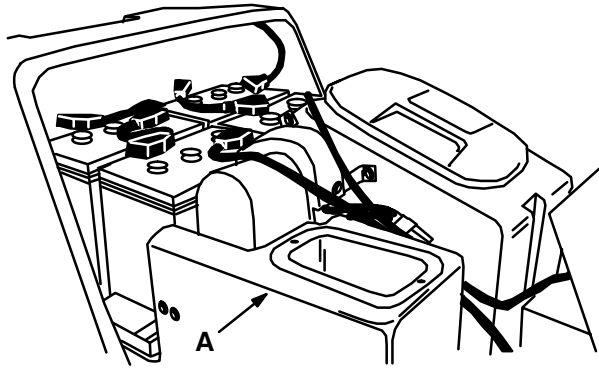

SOLUTION TANK

04378

A. Solution Tank

The solution tank requires no regular maintenance. If detergent cakes on the bottom of the tank, remove the deposits with a strong blast of warm water. Do not use water hotter than 130° F (54° C) or use steam to clean the tank as it will damage it. A tank drain port has been provided to allow the tank to be drained for cleaning and storage.

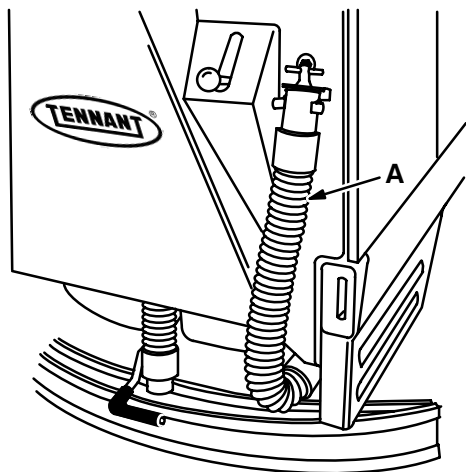

SOLUTION TANK DRAIN

04356

A. Drain Hose

SOLUTION VALVE

The solution valve controls the flow of solution to the scrub brushes. The valve cable should provide the valve with fully open, partially open and fully closed positions.

The solution control cable can be adjusted at the solution lever or valve ends of the cable. To adjust the cable at the solution lever end, remove the rear cover panel of the machine. To adjust the cable at the solution valve end of the cable, remove the right lower panel of the machine to gain access to the solution valve.

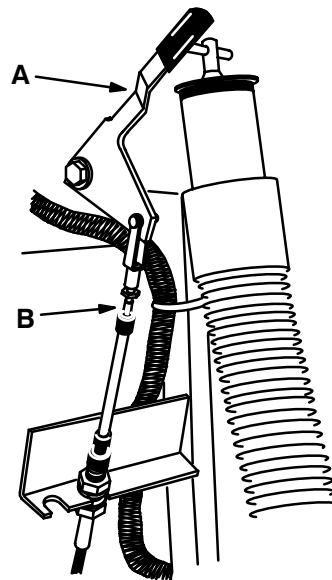

SOLUTION LEVER

04357

- A. Solution Lever
- B. Solution Control Cable

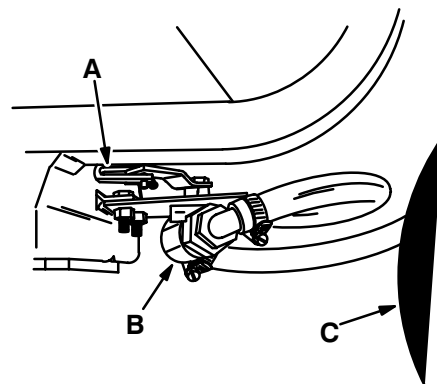

SOLUTION VALVE

04395

- A. Solution Cable
- B. Solution Valve
- C. Front Tire

RECOVERY TANK

The recovery tank stores the water solution picked up by the machine squeegee and vacuum fan. The recovery tank is located on the left side of the machine.

The recovery tank should be drained and cleaned after the solution tank is empty and whenever the float stops the vacuum fan or the recovery tank full lamp lights.

TO DRAIN AND CLEAN RECOVERY TANK

1. Move the solution lever all the way down to stop solution flow.
2. Press the scrub brush switch to stop and raise the brushes.
3. Press the squeegee switch to raise the squeegee and stop the vacuum.
4. Stop the machine next to a floor drain.
5. Turn off the machine and set the machine parking brake, if equipped.

FOR SAFETY: Before Leaving Or Servicing Machine; Stop On Level Surface, Set Parking Brake (If Equipped), And Turn Off Machine And Remove Key.

6. Remove and unplug the drain hose into a floor drain.

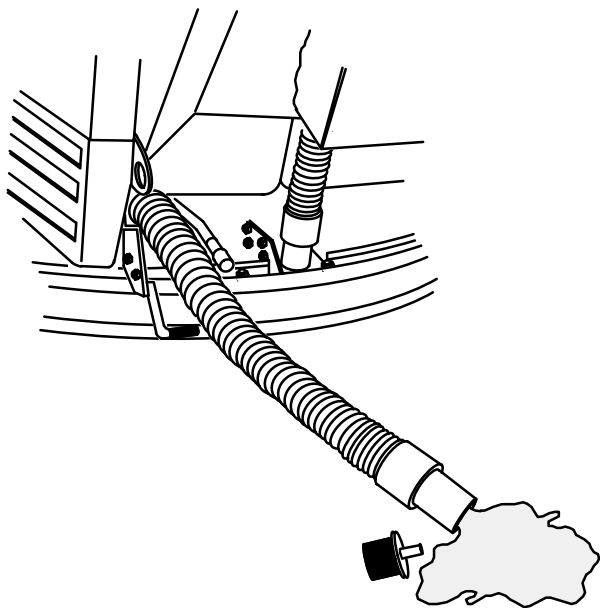

DRAINING RECOVERY TANK

04349

7. Open the machine hood.
8. Remove the recovery tank cover and duct assembly.
9. Spray the inside of the recovery tank with clean water. Remove and clean the fan inlet screen, then place it back into the recovery tank. If the screen is not replaced, damage to the vacuum fan motor could take place. Do not use water hotter than 130° F (54° C) or use steam to clean the tank as it will damage it.

ES™ machines: Flush the ES™ outlet filter and the solution tank outlet filter with water. Then add enough water to cover the recovery tank ES™ outlet filter and operate the ES™ pump to flush the system.

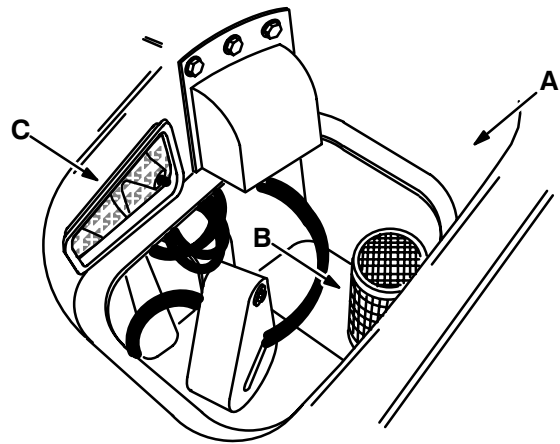

ES™ RECOVERY TANK OUTLET FILTER

04350

- A. Recovery Tank
- B. ES™ Outlet Filter
- C. Fan inlet Screen

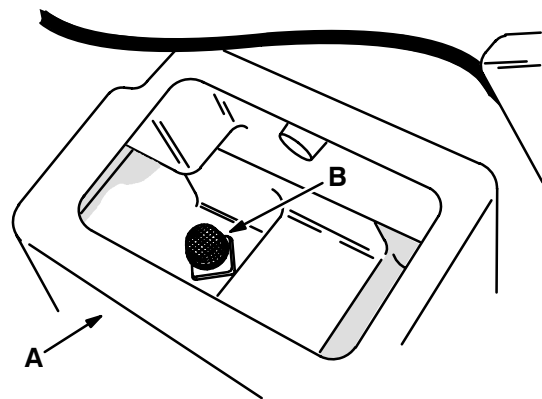

SOLUTION TANK OUTLET FILTER

04355

- A. Solution Tank
- B. Solution Tank Outlet Filter

MAINTENANCE

10. Make sure to hold up the vacuum outlet flap when placing the duct assembly in the recovery tank opening. Replace the recovery tank lid.

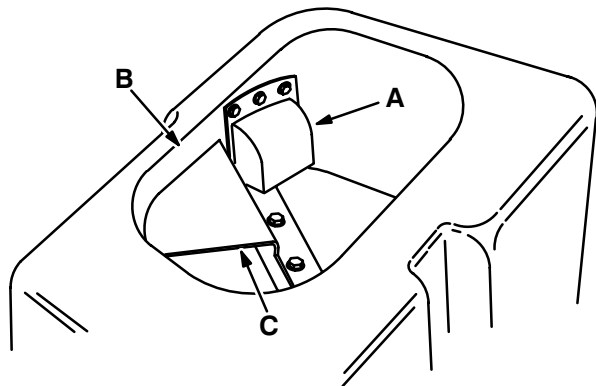

VACUUM FAN DUCT ASSEMBLY

04377

- A. Vacuum Outlet Flap
- B. Recovery Tank Opening
- C. Duct Assembly

11. Remove the squeegee suction hose

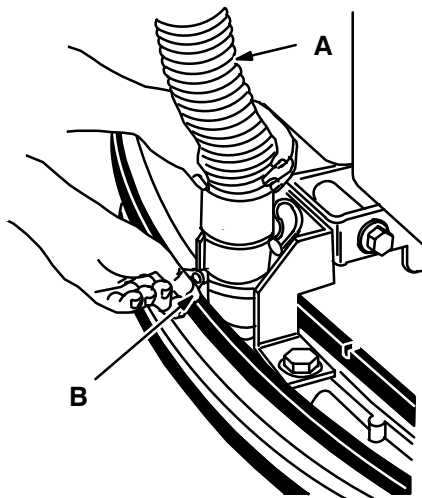

REMOVING SQUEEGEE SUCTION HOSE

04373

- A. Squeegee Hose
- B. Clamp

12. Push a garden hose into the end of the squeegee suction hose. Turn on the vacuum. Turn on the garden hose.
13. Work the garden hose up the squeegee suction hose to flush away any debris.

14. Turn off the garden hose and vacuum. Remove the garden hose from the suction hose and push the suction hose onto the squeegee frame. Tighten the hose clamp around the suction hose.

15. Close the machine hood.

16. Plug and secure the drain hose in its storage clip.

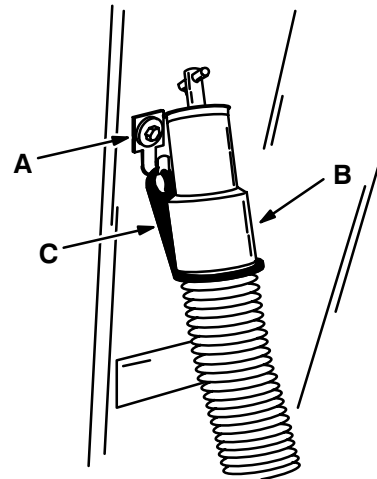

SECURED DRAIN HOSE

04358

- A. Storage Clip
- B. Drain Hose
- C. Hose Strap

SQUEEGEES

REAR SQUEEGEE

The rear squeegee assembly channels water into the vacuum fan suction. It has two squeegee blades. The front squeegee blade channels the water, and the rear blade wipes the floor.

The squeegee assembly can be removed easily for loading and unloading on trailers or to allow the machine to pass through narrow doorways or passageways.

Check the rear squeegee assembly for damage, wear, and adjustment daily. Rotate or replace either squeegee blade if its leading edge is torn or worn half-way through the thickness of the blade.

The front squeegee blade has two wiping edges for scrubbing smooth floors (the edges with multiple slits), and two wiping edges for scrubbing grouted tile floors (the edges with one slit). To use the wiping edges, start with one wiping edge, then rotate the blade end-for-end to use the other wiping edge.

The rear squeegee blade has four wiping edges. To use them all, start with one wiping edge. To use the next wiping edge, rotate the squeegee blade end-for-end. To use the next wiping edge, rotate the top edges of the squeegee blade down, bottom edges up. To use the last wiping edge, rotate the squeegee blade end-for-end.

The squeegee assembly can be adjusted for leveling and deflection. Level the squeegee to assure even contact with the surface to be scrubbed, and deflection for the amount of curl the squeegee has when in contact with the scrubbing surface.

The level and deflection of the squeegee should be checked every 25 hours of operation, or when scrubbing a different type of surface.

TO REMOVE SQUEEGEE ASSEMBLY

1. Raise the rear squeegee.
2. Turn off the machine and set the machine parking brake, if equipped.

FOR SAFETY: Before Leaving Or Servicing Machine; Stop On Level Surface, Set Parking Brake (If Equipped), And Turn Off Machine And Remove Key.

3. Loosen the squeegee hose clamp.

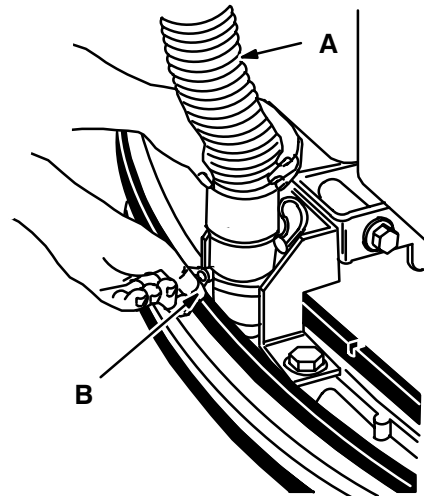

04373

LOOSENING HOSE CLAMP

- A. Squeegee Hose
- B. Clamp

4. Pull the squeegee suction hose off the squeegee frame.
5. Disconnect the stabilizing link by pulling the ball joint sleeve back and up.
6. Pull the retaining pin out of the squeegee pivot.

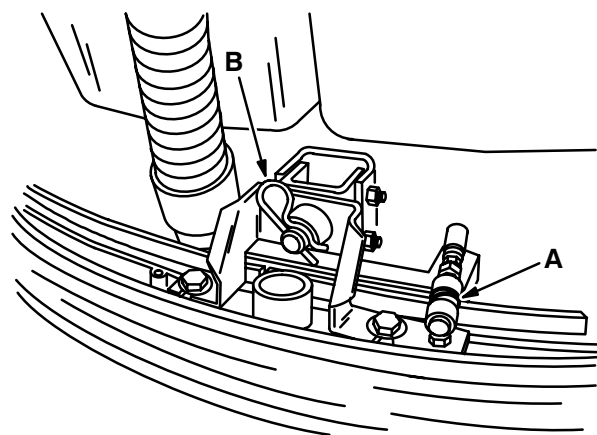

04374

SQUEEGEE PIVOT

- A. Stabilizing Link
- B. Retaining Pin

7. Slide the squeegee assembly off the squeegee pivot.

MAINTENANCE

TO INSTALL SQUEEGEE ASSEMBLY

1. Slide the squeegee assembly onto the squeegee pivot.
2. Press the retaining pin through the squeegee pivot.
3. Reconnect the stabilizing link by pulling the ball joint sleeve and pushing it onto the ball joint stud on the squeegee assembly.
4. Push the squeegee suction hose onto the squeegee frame.
5. Tighten the squeegee hose clamp.

TO REPLACE OR ROTATE BLADE

1. Raise the squeegee.
2. Turn off the machine and set the machine parking brake, if equipped.

FOR SAFETY: Before Leaving Or Servicing Machine; Stop On Level Surface, Set Parking Brake (If Equipped), And Turn Off Machine And Remove Key.

3. Remove the pin, deflector, and gasket from the end of the squeegee.

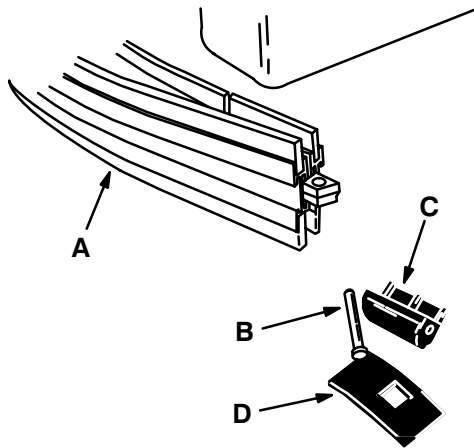

SQUEEGEE

04369

- A. Squeegee
- B. Pin
- C. Deflector
- D. Gasket

4. Pull the squeegee blade off the squeegee frame.

5. Replace or rotate the squeegee to allow a new edge to face the front of the machine.
6. Slide the squeegee blade onto the squeegee frame.

NOTE: Lubricating the squeegee frame where the squeegee makes contact will make for easier squeegee installation.

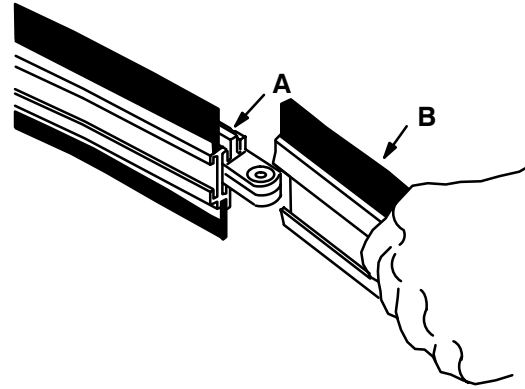

04370

REPLACING SQUEEGEE BLADE

- A. Squeegee Frame
- B. Squeegee Blade

7. Place the squeegee gasket on the end of the squeegee frame with the long end down and back.

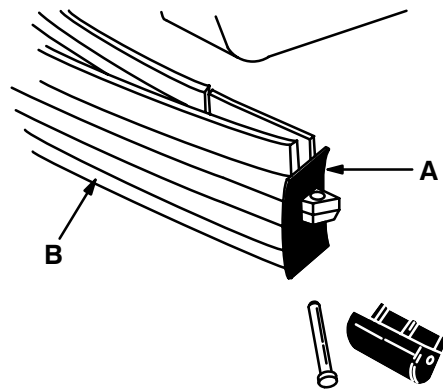

SQUEEGEE GASKET

04371

- A. Gasket
- B. Squeegee

8. Replace squeegee deflector and pin.
9. Adjust the rear squeegee as described in *TO LEVEL REAR SQUEEGEE* and *TO ADJUST SQUEEGEE DEFLECTION*.

TO LEVEL REAR SQUEEGEE (for 1465 with serial number below 030065, or 1480 with serial number below 040161)

1. Lower the rear squeegee and move the machine forward.
2. Turn off the machine and set the machine parking brake, if equipped, with the squeegee lowered.

FOR SAFETY: Before Leaving Or Servicing Machine; Stop On Level Surface, Set Parking Brake (If Equipped), And Turn Off Machine And Remove Key.

3. Observe the level of the squeegee for an even curl along the length of the blade.
4. Loosen the turnbuckle jam nuts.

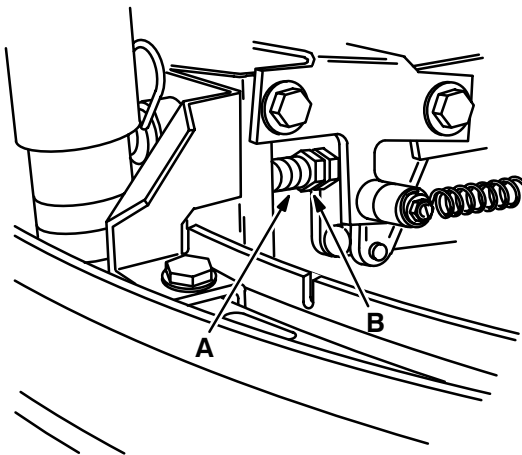

SQUEEGEE LEVEL ADJUSTMENT

04391

- A. Jam Nut
- B. Turnbuckle

5. Adjust the turnbuckle to increase or decrease the curl at the ends of the squeegee assembly.
6. Turn on the machine. Lower the squeegee. Move the machine forward and observe the level of the squeegee. Readjust if necessary until an even curl is achieved along the length of the squeegee.
7. Turn the machine off with the squeegee lowered. Tighten the turnbuckle jam nuts.

TO LEVEL REAR SQUEEGEE (for 1465 serial number 030065 and above, 1480 serial number 040161 and above, and 1490 machines)

1. Lower the rear squeegee and move the machine forward.
2. Turn off the machine and set the machine parking brake, if equipped.

FOR SAFETY: Before Leaving Or Servicing Machine; Stop On Level Surface, Set Parking Brake (If Equipped), And Turn Off Machine And Remove Key.

3. Observe the level of the squeegee for an even curl along the length of the blade.
4. Loosen the jam nut on the adjustment screw. Loosen the pivot screw.

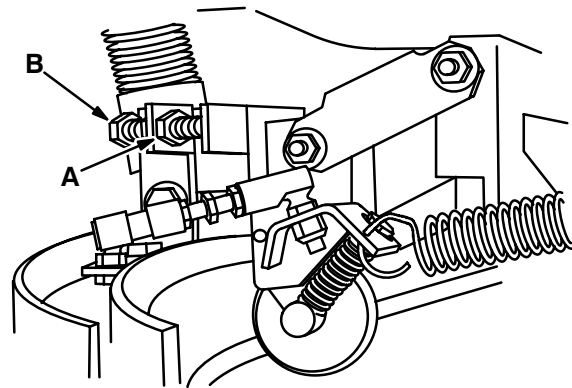

LEVEL ADJUSTMENT SCREW

05489

- A. Jam Nut
- B. Adjustment Screw

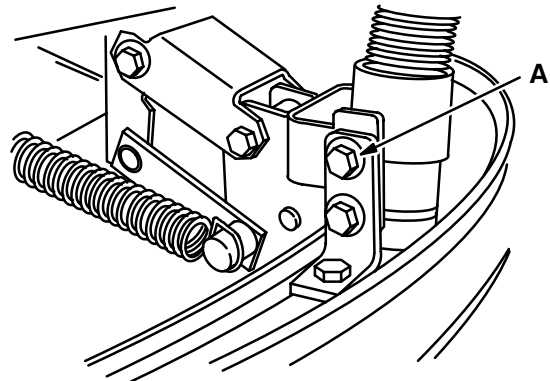

PIVOT SCREW

05491

- A. Pivot Screw

MAINTENANCE

5. Turn the adjustment screw counter-clockwise to increase the curl at the tips of the squeegee assembly. Turn the adjustment screw clockwise to decrease the curl at the ends of the squeegee assembly.
6. Turn on the machine, release the parking brake (if equipped), and move the machine forward to observe the curl along the length of the squeegee. Readjust the tip curl if necessary.
7. Tighten the jam nut on the adjustment screw and tighten the pivot screw.

TO ADJUST SQUEEGEE DEFLECTION (for 1465 with serial number below 030065, or 1480 with serial number below 040161)

1. Lower the rear squeegee and move the machine forward.
2. Turn off the machine and set the machine parking brake, if equipped, with the squeegee lowered.

FOR SAFETY: Before Leaving Or Servicing Machine; Stop On Level Surface, Set Parking Brake (If Equipped), And Turn Off Machine And Remove Key.

3. Observe the amount of squeegee deflection. It should deflect 0.50 in (13 mm) across its entire width for smooth floors and 0.62 in (15 mm) for rough floors.

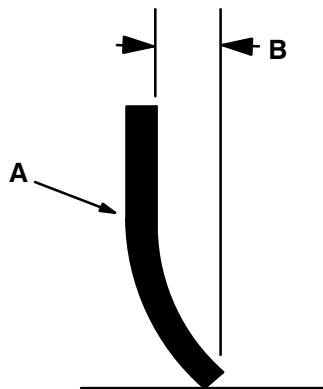

SQUEEGEE DEFLECTION

03719

- A. Squeegee
- B. Deflection

4. Loosen the jam nut on the down pressure adjustment screw located at the front of the squeegee pivot assembly.

To increase the squeegee deflection, turn the screw clockwise.

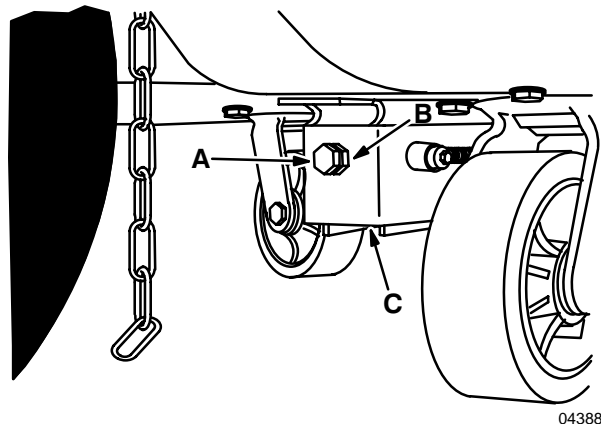

04388

DEFLECTION ADJUSTMENT

- A. Down Pressure Adjustment Screw
- B. Jam Nut
- C. Squeegee Pivot Assembly

To decrease the squeegee deflection, turn the screw counter-clockwise.

5. Turn on the machine. Lower the squeegee. Move the machine forward and observe the deflection of the squeegee. Readjust if necessary until the suggested deflection is reached.
6. Tighten the jam nut on the down pressure adjustment screw.

TO ADJUST SQUEEGEE DEFLECTION (for 1465 serial number 030065 and above, 1480 serial number 040161 and above, and 1490 machines)

1. Lower the rear squeegee and move the machine forward.
2. Turn off the machine and set the machine parking brake, if equipped.

FOR SAFETY: Before Leaving Or Servicing Machine; Stop On Level Surface, Set Parking Brake (If Equipped), And Turn Off Machine And Remove Key.

3. Observe the amount of squeegee deflection. It should deflect 0.62 in (15 mm) across its entire width.

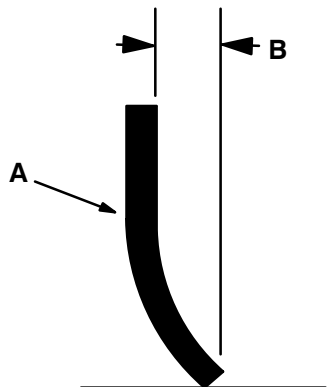

SQUEEGEE DEFLECTION

- A. Squeegee
- B. Deflection

03719

4. To increase the amount of squeegee blade deflection, loosen the lock nut, turn the squeegee caster height adjustment screw clockwise, then tighten the lock nut. To decrease the amount of squeegee blade deflection, loosen the lock nut, turn the squeegee caster height adjustment screw counter-clockwise, then tighten the lock nut.

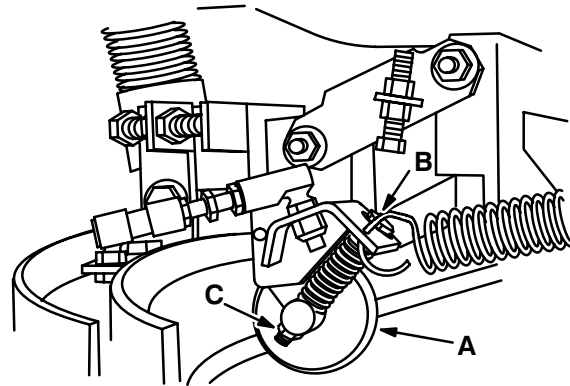

05489

SQUEEGEE HEIGHT ADJUSTMENT

- A. Caster
- B. Squeegee Caster Height Adjustment Screw
- C. Lock Nut

5. Turn on the machine, release the parking brake (if equipped), and move the machine forward to observe the squeegee blade deflection. Readjust the deflection if necessary.

NOTE: The tip curl at the ends of the squeegee assembly may have to be readjusted after a proper deflection has been achieved.

BRAKES AND TIRES**PARKING BRAKE**

The parking brake is present on machines with the parking brake option. It controls the brakes on the front wheels.

The parking brake should be adjusted after every 100 hours of operation or whenever it becomes easy to engage it.

To adjust the parking brake, adjust the tension of the brake cables at the brake bracket near the brake lever. Loosen the mounting nut, turn the brake cable nut on the other side of the brake bracket clockwise to increase the tension on the brake cable. Tighten the mounting nut.

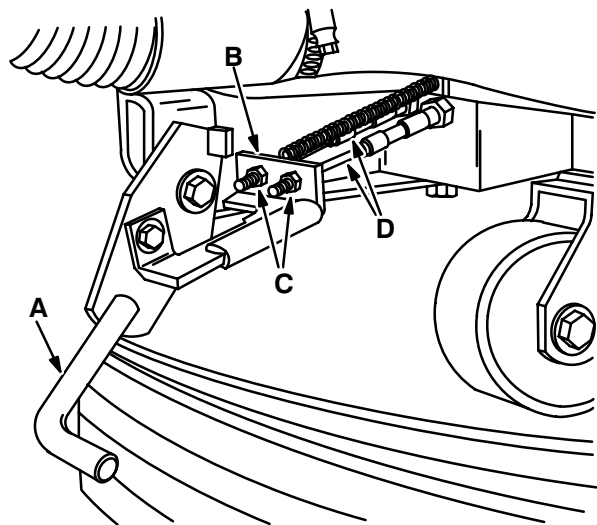
**PARKING BRAKE ADJUSTMENT**

04393

- A. Brake Lever
- B. Brake Bracket
- C. Mounting Nut
- D. Brake Cable

TIRES

The two front tires support the weight of the front of the machine. They are pneumatic. Check the air pressure after every 25 hours of operation. The correct air pressure is 40 to 45 psi (275 to 310 kPa). For the 1480 with the heavy duty batteries option, the correct air pressure is 60 to 65 psi (410 to 450 kPa).

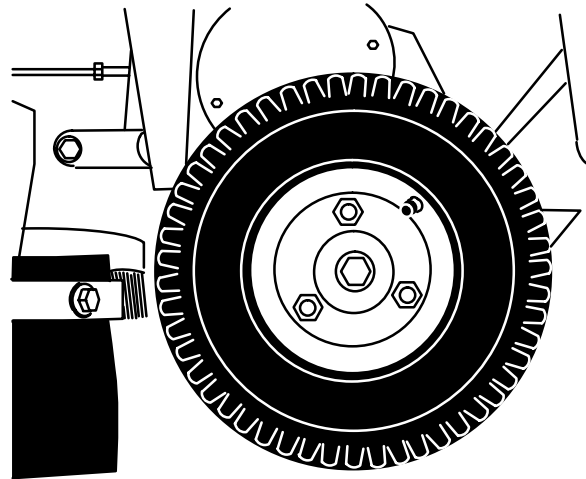
**TIRE**

04376

OPTIONS

PRE-SWEEP™

The Pre-Sweep™ allows the machine to pick up small debris. Maintenance of the Pre-Sweep™ assembly includes; adjustment of the brush pattern, height adjustment of the brush side skirts, checking drive belt tension and wear, and replacement of seals and flaps as they become damage or worn.

PRE-SWEEP™ BRUSH

The Pre-Sweep™ brush deposits small debris in the hopper. It should be checked daily for wear and damage. Remove any string or wire found tangled on the brush, brush drive hub, or brush idler arm.

Check the main brush pattern every time a new brush is installed. The brush should be replaced whenever the bristles measure 0.38 to 0.50 in (10 to 13 mm) in length.

TO REPLACE PRE-SWEEP™ BRUSH

1. Turn the machine off and set the machine parking brake, if equipped.

FOR SAFETY: Before Leaving Or Servicing Machine; Stop On Level Surface, Set Parking Brake (If Equipped), And Turn Off Machine And Remove Key.

2. Remove the debris hopper.
3. Lower the Pre-Sweep™ brush.
4. Remove the two mounting screws holding the brush idler plate to the Pre-Sweep™ frame.

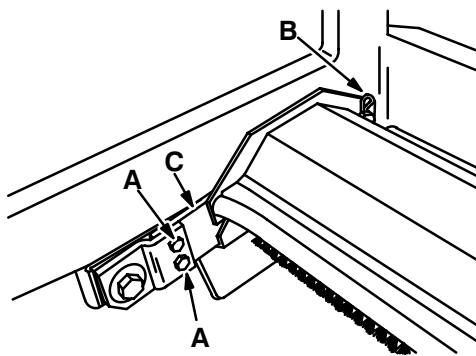

PRE-SWEEP™ BRUSH IDLER

04396

- A. Mounting Screws**
- B. Cotter Pin**
- B. Brush Idler Plate**

5. Pull out the cotter pin holding the idler plate to the brush frame.
6. Pull out the brush idler plate.
7. Remove the brush.



04397

REMOVING PRE-SWEEP™ BRUSH

8. Line up the drive end of the new brush with the brush drive plug.
9. Line up the idler plate with the idler end of the new brush. Line the pins on the idler plate up with holes on the brush frame.

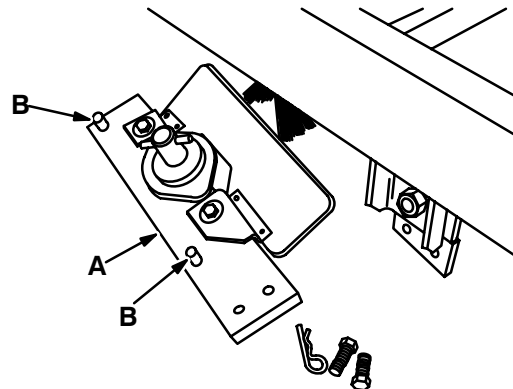

04400

LINING UP THE IDLER PLATE

- A. Idler Plate**
- B. Pins**

10. Install the cotter pin to hold the idler plate to the brush frame.
11. Secure the brush idler plate to the Pre-Sweep™ frame with the two mounting screws.
12. Check the brush pattern as described in *TO ADJUST PRE-SWEEP™ BRUSH PATTERN.*

MAINTENANCE

TO ADJUST PRE-SWEEP™ BRUSH PATTERN

1. Apply chalk, or some other material that will not blow away easily, to a smooth, level floor.
2. Turn the machine on and park the Pre-Sweep™ assembly over the chalked area. Turn the machine off and set the parking brake, if equipped.

FOR SAFETY: Before Leaving Or Servicing Machine; Stop On Level Surface, Set Parking Brake (If Equipped), And Turn Off Machine And Remove Key.

3. Lower the Pre-Sweep™ brush.
4. Turn the machine on and allow the brush to spin on the chalked area for 15 to 20 seconds.

NOTE: If no chalk or other material is available, allow the brush to spin on the floor for two minutes.

5. Look at the brush pattern. It should measure 0.75 to 1.25 in (20 to 30 mm) across the length of the brush.
6. To adjust the pattern width, loosen the wing nut on the brush handle. Turn the nut located below the brush handle bracket. Tighten the wing nut when the desired width is reached.

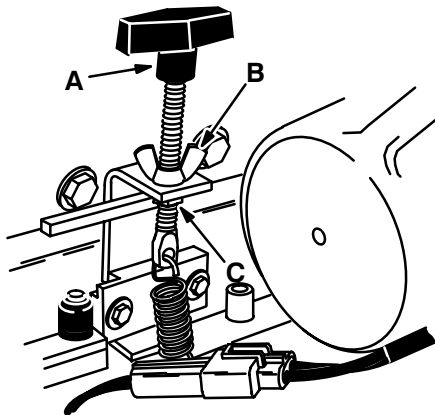

BRUSH PATTERN ADJUSTMENT

04392

- A. Brush Handle
- B. Wing Nut
- C. Nut

7. Replace the debris hopper.

PRE-SWEEP™ BRUSH SIDE SKIRTS

The Pre-Sweep™ brush side skirts are located on either side of the Pre-Sweep™ brush

The Pre-Sweep™ brush side skirts should be adjusted so there is a maximum of 0.03 in (1 mm) space between the floor and the bottom of the skirt. Check the side skirt clearance after 80 hours of operation.

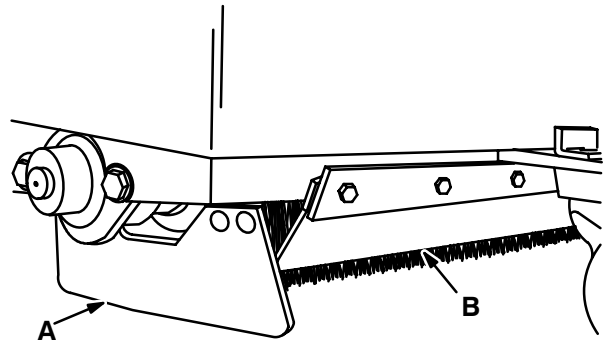

PRE-SWEEP™ SIDE SKIRT

04398

- A. Side Skirt
- B. Rear Skirt

PRE-SWEEP™ BRUSH DRIVE BELT

The Pre-Sweep™ brush drive belt transfers power from the Pre-Sweep™ brush motor to the brush. The belt tension should be checked every 80 hours of operation. The belt is properly tensioned when the belt deflects 0.11 in (3 mm) from a force of 3.6 to 5.4 lb (1.6 to 2.5 kg).

TO REPLACE AND ADJUST THE BRUSH DRIVE BELT

1. Turn the machine off and set the parking brake, if equipped.

FOR SAFETY: Before Leaving Or Servicing Machine; Stop On Level Surface, Set Parking Brake (If Equipped), And Turn Off Machine And Remove Key.

2. Remove the debris hopper.
3. Remove the belt cover.

- Loosen the four adjustment bolts on either side of the belt.

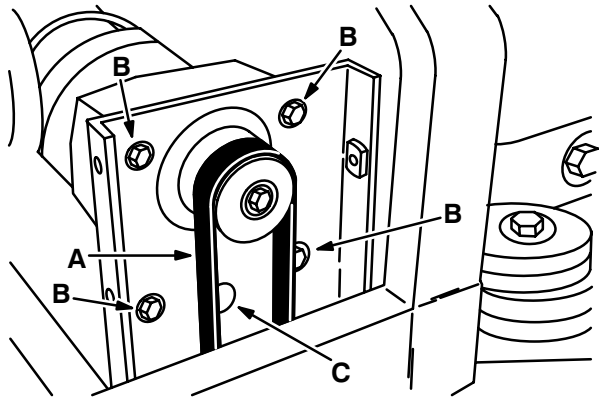

04394

PRE-SWEEP™ DRIVE BELT

- A. Drive Belt**
- B. Adjustment Bolts**
- C. Pry Hole**

- Remove the old belt.
- Place the new belt on the sheaves.
- Place a large screwdriver in the pry hole and put tension on the belt. Tighten the four adjustment bolts. Check the tension, and readjust if necessary.
- Replace the belt cover.
- Replace the debris hopper.

PRE-SWEEP™ REAR SKIRT

The Pre-Sweep™ rear skirt helps keep debris away from the scrub brushes. It is located behind the Pre-Sweep™ brush. Check the rear skirt every 25 hours of operation for damage and wear.

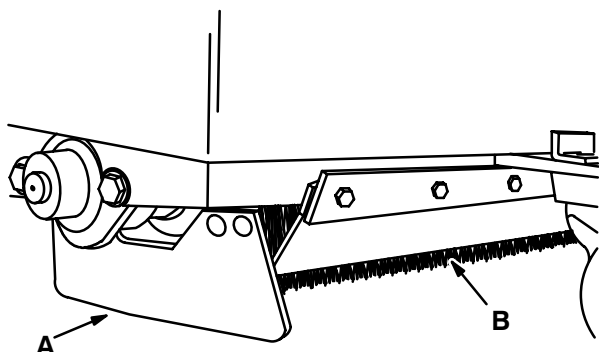

04398

PRE-SWEEP™ REAR SKIRT

- A. Side Skirt**
- B. Rear Skirt**

MAINTENANCE

DEBRIS HOPPER SLIT SKIRT

The debris hopper slit skirt helps direct debris into the hopper. It is located at the bottom rear of the debris hopper. The rear lip of the slit should always lie flat and contact the floor. Check the skirt every 25 hours of operation for damage or wear.

PRE-SWEEP™ HOPPER SEALS

There are several seals to seal the debris hopper. One seal is located on the Pre-Sweep™ frame where the debris hopper comes in contact with the frame. There is also two seals located on the both sides of the debris hopper. Check these seals every 25 hours of operation for damage or wear.

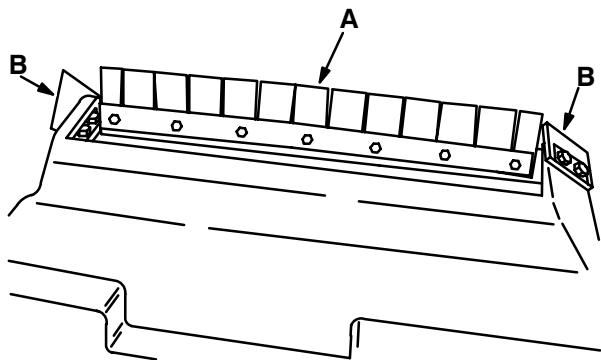

04399

PRE-SWEEP™ HOPPER SKIRTS AND SEALS

- A. Hopper Slit Skirt
- B. Hopper Seal

SECTION 4

CONTENTS

| | Page |
|---|------|
| HARDWARE INFORMATION | 4-3 |
| STANDARD BOLT TORQUE CHART ... | 4-3 |
| METRIC BOLT TORQUE CHART | 4-3 |
| BOLT IDENTIFICATION | 4-3 |
| THREAD SEALANT AND LOCKING COMPOUNDS | 4-3 |

HARDWARE INFORMATION

The following charts state standard plated hardware tightening ranges for normal assembly applications. Decrease the specified torque by 20% when using a thread lubricant. Do not substitute lower grade hardware for higher grade hardware. If higher grade hardware than specified is substituted, tighten only to the specified hardware torque value to avoid damaging the threads of the part being threaded into, as when threading into speed nuts or weldments.

STANDARD BOLT TORQUE CHART

| Thread Size (Nm) | SAE Grade 5 Torque ft lb (Nm) | SAE Grade 8 Torque ft lb |
|------------------|-------------------------------|--------------------------|
| 0.25 in | 7–10 (9–14) | 10–13 (14–38) |
| 0.31 in | 15–20 (20–27) | 20–26 (27–35) |
| 0.38 in | 27–35 (37–47) | 36–47 (49–64) |
| 0.44 in | 43–56 (58–76) | 53–76 (72–103) |
| 0.50 in | 65–85 (88–115) | 89–116 (121–157) |
| 0.62 in | 130–170 (176–231) | 117–265 (159–359) |
| 0.75 in | 215–280 (291–380) | 313–407 (424–552) |
| 1.00 in | 500–650 (678–881) | 757–984 (1026–1334) |

NOTE: Decrease torque by 20% when using a thread lubricant.

METRIC BOLT TORQUE CHART





| Thread Size (Nm) | Class 8.8 Torque ft lb (Nm) | Class 10.9 Torque ft lb |
|------------------|-----------------------------|-------------------------|
| M4 | 2 (3) | 3 (4) |
| M5 | 4 (5) | 6 (8) |
| M6 | 7 (9) | 10 (14) |
| M8 | 18 (24) | 25 (34) |
| M10 | 32 (43) | 47 (64) |
| M12 | 58 (79) | 83 (112) |
| M14 | 94 (127) | 133 (180) |
| M16 | 144 (195) | 196 (265) |
| M20 | 260 (352) | 336 (455) |
| M24 | 470 (637) | 664 (900) |

NOTE: Decrease torque by 20% when using a thread lubricant.

Exceptions to the above chart:

Not available at time of publication.

BOLT IDENTIFICATION

| Identification Grade Marking | Specification and Grade |
|---|-------------------------|
|  | SAE–Grade 5 |
|  | SAE–Grade 8 |
|  | ISO–Grade 8.8 |
|  | ISO–Grade 10.9 |

01395

THREAD SEALANT AND LOCKING COMPOUNDS

Thread sealants and locking compounds may be used on this machine. They include the following:

Loctite 515 sealant – gasket forming material. TENNANT® Part No. 75567, 15 oz (440 ml) cartridge.

Loctite 242 blue – medium strength thread locking compound. TENNANT® Part No. 32676, 0.5 ml tube.

Loctite 271 red – high strength thread locking compound. TENNANT® Part No. 19857, 0.5 ml tube.

